

Hot water - High pressure cleaner



630

230V / 50/60Hz

Operating instructions
Read and conform
before use

Technical data

Dear Customer

We would like to congratulate you on your new hot water high pressure cleaner, and to thank you for buying it!

The following pages contain information about the machine in order to familiarise you with it and facilitate its use.

The machine is a professional cleaning aid in all cleaning tasks, eg:

- **Facades**
- **Vehicles of all types**
- **Containers**
- **Paving slabs**
- **Stables**
- **Machinery**
- **Removal of old paint, etc.**

Technical specifications	therm 630
Operating pressure,	30 - 130 bar
Nozzle	045
Admissible overpressure	145 bar
Water consumption	max. 630 l/hr
Hot water output	max. 80 °C
Contin. adjustable steam level	max. 150 °C
High pressure hose	10 m
with hose drum	20 m
Heating oil consumption	3,5 kg/hr - heating oil EL (DIN 51 603)
Heating power	44 kW
Exhaust gas mass flow	0,028 kg/s
Electrical rating:	230V / 50/60Hz / 14,5A
Input	P1: 3,1 kW
Output	P2: 2,3 kW
Weight	200 kg
Dimensions in mm without reel	800 x 1200 x 1050
Sound level acc.to 45635	84 dB (A)
Guaranteed sound level L_{WA}	88 dB (A)
Vibrations at lance	2,0 m/s ²
Recoil to lance	approx. 20 N

Admissible deviation to values $\pm 5\%$ according to VDMA sheet 24 411

Description

Construction and Function

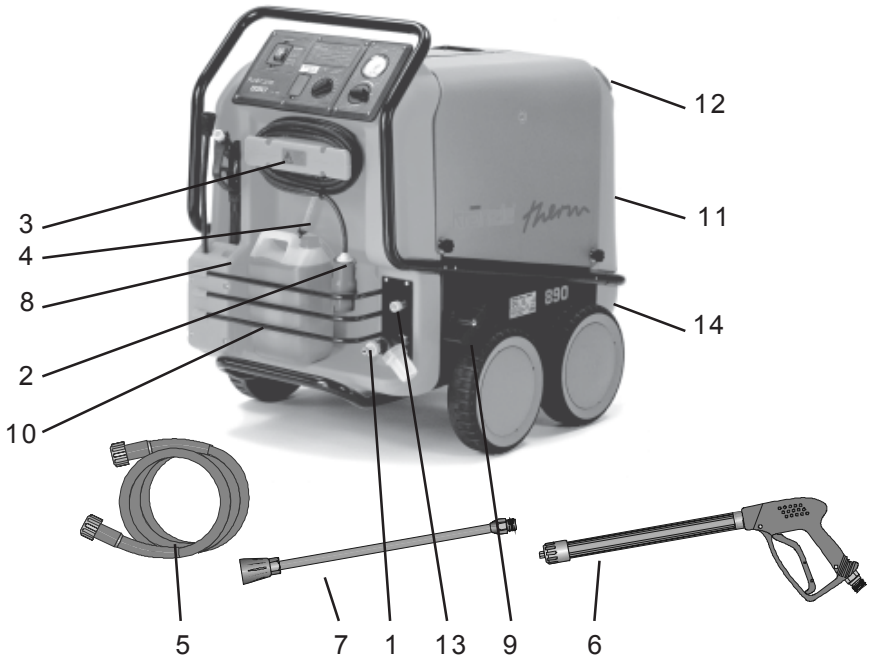

- | | | | |
|---|------------------------------------|----|------------------------------------|
| 1 | Water inlet connection with filter | 8 | Storage bin for spray gun and pipe |
| 2 | Power cable | 9 | Brake |
| 3 | Winder for cable | 10 | Storage bin for accessories |
| 4 | Suction hose for detergent | 11 | Fuel tank |
| 5 | High pressure hose | 12 | Filler aperture for fuel |
| 6 | Spray gun | 13 | High pressure outlet |
| 7 | Spray pipe attachment | 14 | Fuel drainage screw |

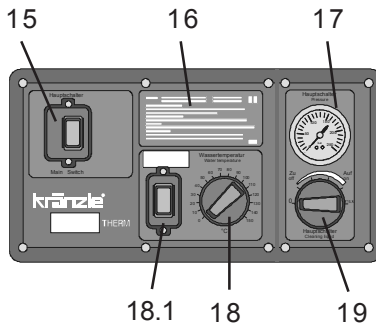

- | | | | |
|----|-----------------------------------|------|----------------------------|
| 15 | Master switch (appliance On- Off) | 18 | Thermostat |
| 16 | Brief operating instructions | 18.1 | (Burner ON- OFF) ignition |
| 17 | Manometer | 19 | Detergent dispensing valve |

Description

Water system

The water flows into a tank.

A float valve regulates the water intake.

The water is then directed to the safety spray pipe under pressure from the high pressure pump.

The high pressure spray is formed through the nozzle on the spray pipe.

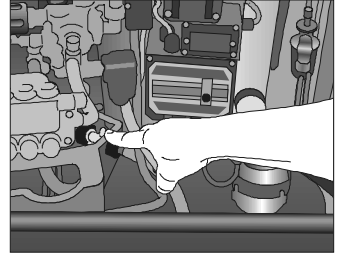

Detergent and caring system

The high pressure pump can also suck a detergent/caring agent and mix it with the high pressure jet. - The detergent must have the ph-value 7-9 neutral.



Only open the dosing valve, if the chemistry sieve is placed in a liquid.

The rules concerning the environment, refuse and ground water protection must be complied with!

Pressure control and safety facilities

The pressure control valve allows full adjustment of the quantity and pressure of the water.

The safety valve protects the machine from excessive pressure and cannot be adjusted beyond the admissible operating pressure. The setting nuts are sealed with lacquer.

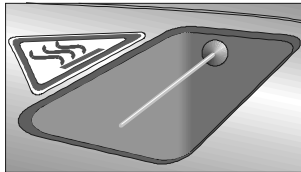
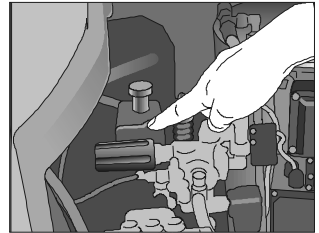

As an additional safety feature against overheating of the combustion chamber a temperature sensor is installed in the chimney. This sensor switches off the burner motor, the ignition transformer and the solenoid valve as soon as the exhaust gas temperature exceeds 250° C.

You find the unlocking button for the excess temperature release on the console fixed to the combustion chamber below the ignition transformer.

The machine has to rest for approx. 15 minutes before it is allowed to press the unlocking button. If the excess temperature sensor switches the machine off repeatedly please call the technical service.

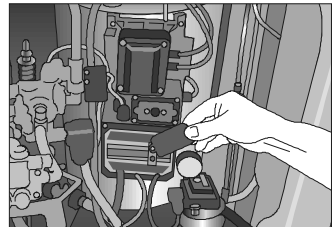

Replacements, repairs, new adjustments and sealing operations may only be performed by trained personnel.

Description

Motor protection switch

The pump motor is protected from overload by a motor protecting switch. In case of an overload the motor is switched off by the motor protecting switch. In case the blue button is not set to „automatic resetting“, it has to be pushed in again by hand. In case of a repeated switching off of the motor by the motor protecting switch the cause of the malfunction has to be removed.

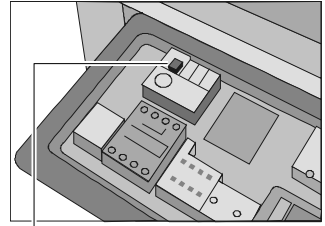

Blue button in the unfolded control panel



Replacement and inspection work may only be performed by trained personnel.

Spray pipe with spray gun

The spray gun only allows the machine to be operated when the safety trigger is pulled.

The spray gun can be used when the safety trigger is pulled. The liquid is then pumped up to the nozzle. Spray pressure builds up and quickly reaches the selected operating pressure.

When the trigger is released the gun is closed, which prevents any further liquid from coming out of the spray pipe.

The recoil resulting from the gun being closed opens the pressure control valve in the machine. The pump remains switched on and pumps the circuit with reduced overpressure. When the gun is opened (trigger pressed) the pressure control valve closes and the pump starts to operate again at the selected pressure.

After completing work with your Kränzle therm, or if work is interrupted, the safety catch (1) must be applied. This makes it impossible to press the trigger by accident.

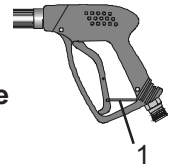
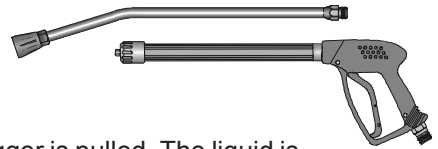

The spray gun is a safety device. Repairs may only be performed by trained personnel. If spare parts are required, use only those approved by the maker.

Thermostat

The thermostat with rotary control switch controls the temperature of the spray water.

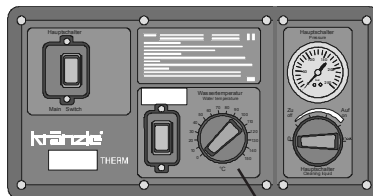

Thermostat with rotary control switch

Safety Information

Brake

The Kränzle therm is fitted with a brake that prevents the machine from rolling away on flat ground.

Always apply the brakes firmly when working with the machine !!!

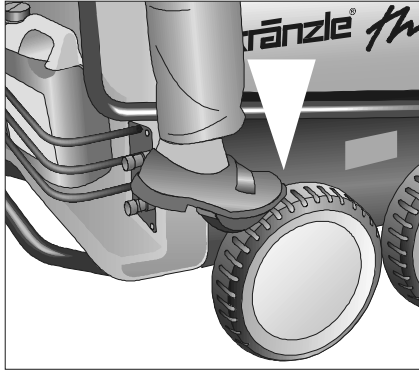

Brake applied

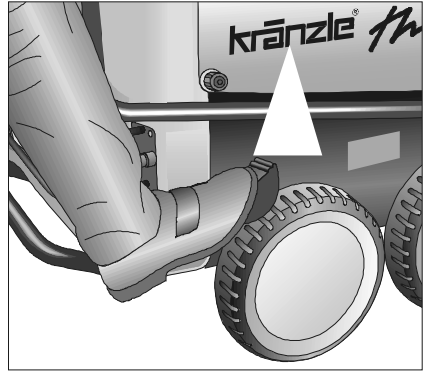

Brake not applied

If you want to move the high pressure cleaner into another direction, first slightly tilt back the machine by pressing the foot rest and pulling the pushbar at the same time.

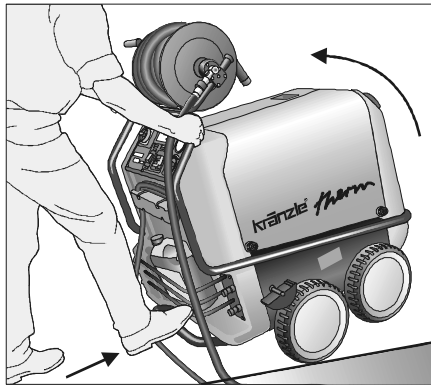

Now you can move the cleaner into the desired direction.

Safety Information



CAUTION !!!

For safety reasons always put the master switch into the „0“ position (=power switch-off) after completion of work.

When starting the cleaning process do not aim the high pressure jet at the object to be cleaned for at least 30 seconds.

It is possible, that the water contents in the combustion chamber (approx. 5 litres) has changed colour due to the resting time.

Description

Heat exchanger

Heating coil: 34 m long - Content: 5 l of water – Heating capacity: 70 k W

The heat exchanger is heated by a high pressure fan heater.

A ventilator (1) draws in the cold, fresh air from the bottom end of the machine and forces it upwards between the outer mantle (2) and the inner mantle (3). In the process, the fresh air is pre-heated and the outer mantle of the heat exchanger is cooled.

The pre-heated air is pressed through a mixing unit (4). Here finely atomised fuel is injected via a nozzle (5) and mixed with the air. The electrodes (6) located below then ignite the fuel-air mixture.

The flame burns from top to bottom, turns round and the hot gas flows past the heating coil (7) on its way back up. The burned gases collect in the exhaust chamber and are emitted from the chimney (8).

The water is forced through a heating coil by the high pressure pump. Hot air flows around the coil, as described above.

The fuel pump (9) draws the oil through a filter (10) and pumps it to the injector nozzle (5). The surplus quantity of fuel flows straight back into the tank. The oil pressure (approx. 10 bar) is shown on the fuel manometer (11).

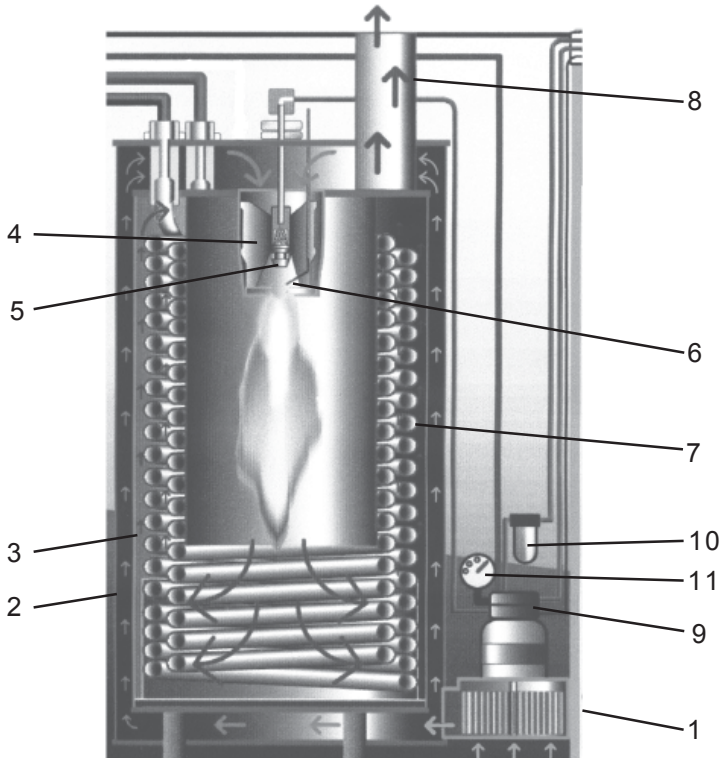

Safety Information

Safety Information

Important!!!



The machine must be disconnected from the power supply when servicing work is being carried out. The master switch should be in position "0" and the plug out of the socket.

Do not use the cleaner if electrical connections or other safety-relevant parts (e.g. overpressure valve, high pressure hose, spraying equipment etc.) are damaged.

The machine may only be used by persons who have received the necessary training.

- Never operate the machine without supervision.
- The water spray can be dangerous. It should never be directed at people, animals, electrical apparatus or the machine itself.
- Never direct the spray at power sockets.
- Parts of the machine interior and parts of the gun and lance become hot when hot water is used. Leave the cover of the machine closed when using the machine and do not touch the metallic parts of the gun and lance.
- Children must not use high pressure cleaning equipment.
- Do not damage the cable or repair it incorrectly.
- Do not pull the high pressure hose if there are kinks or loops in it. Make sure that the hose is not damaged on sharp edges.
- Persons operating the machine should wear the necessary protective clothing, ie, waterproof clothing, rubber boots, safety goggles, headwear etc. It is prohibited to use the machine in close vicinity to people lacking suitable protective clothing.
- The high pressure spray can generate a high level of noise. If noise exceeds the maximum allowed levels, users and others in the vicinity must wear suitable ear protection.
- The high pressure spray causes recoil and additional twisting movement if the gun is angled. The gun must therefore be held firmly with both hands. (see page 2)
- **Do not close off the exhaust aperture on the topside of the machine.** Do not bend over this aperture and do not put your hands inside it. **Exhaust gases are very hot!**
- Do not clamp down the trigger of the gun. Apply the safety catch after use, in order to prevent accidental spraying.
- Do not spray against matter containing asbestos or other hazardous substances.
- Never spray liquids containing solvents, such as paint thinner, petrol, oil, or anything similar. **Note the specifications of the additive makers!** The seals in the machine are not resistant to solvents. The spray vapour of solvents is highly inflammable, explosive and poisonous.

Safety Information

- The machine may not be set up and used in rooms where there is a danger of fire or explosion. The machine may not be used under water.
- Air is required for combustion, and exhaust fumes are generated. If the machine is used in closed rooms, make sure that the exhaust fumes can escape and that there is adequate ventilation.
- Use light heating oil EL (DIN 51 603) or Diesel (DIN EN 590) only. The use of other fuel is perilous and may even cause an explosion.

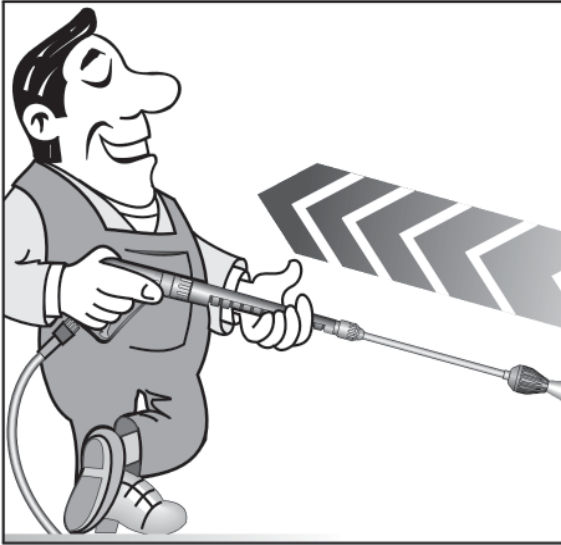

As to the recoil -
see notice on page 2!

Apply the safety catch on the
spray gun after each use, in
order to prevent uninten-
tional spraying!

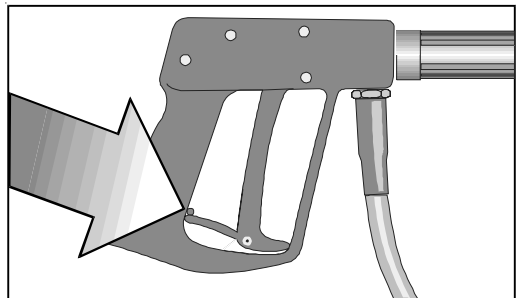

This is prohibited!

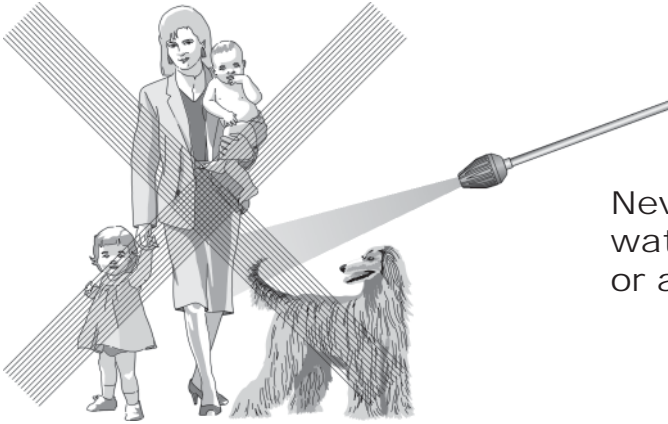

Never direct the water jet at people or animals!

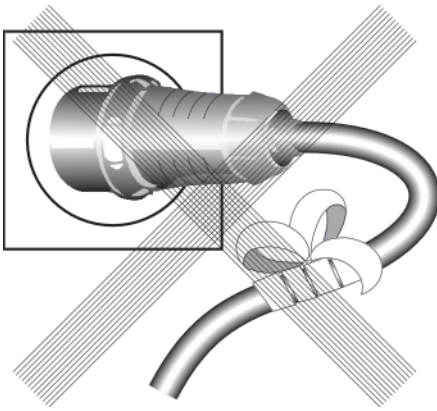

Do not damage the power cable or repair it incorrectly!



Never pull the high pressure hose if it has formed kinks or "nooses"!
Never pull the hose over sharp edges!

This is prohibited!



Never allow children to use the high pressure cleaner!

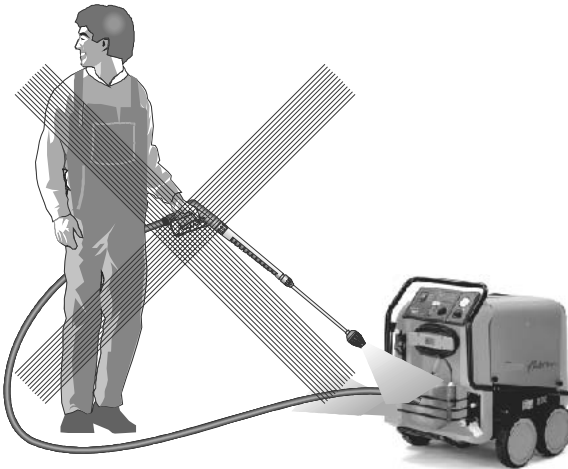

Never direct the water jet at the machine itself!

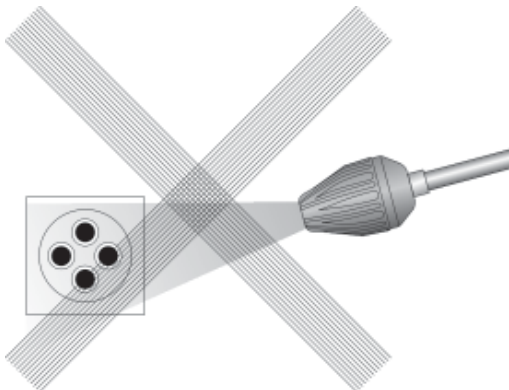

Never direct the water jet at a power socket!

Commissioning

Electrical connection

The voltage given on the specification plate must match the mains voltage.



The machine is supplied with a power cable and plug.

The plug must be connected to a properly installed electrical socket with earthing and have a 30 mA FI residual current circuit breaker. The socket must have a neutral 16A fuse on the mains side.

If an extension cable is used, it must have an earth line that is properly connected to the plug connections. The lines in the extension cable must have a cross section of at least 1,5 mm². The plug connections must be of spray protected design and may not lie on a wet surface. (If the extension cable is longer than 10 m the minimum cross section is 2,5 mm²)



Important!

Extension cables that are too long cause a drop in the voltage and thus interruptions in operation. If you are using a cable drum, the cable must always be fully unwound.

Brief operating instructions

To be found on the machine.

1. Connect the high pressure hose with the spray gun and lance to the machine.
2. Connect the water supply and turn on the tap.
3. Connect to the electrical supply.
4. Switch on the machine with the spray gun open and start the washing procedure.
If the system has to be de-aerated (machine vibrates), open and close the gun several times.
5. When using the machine as a cold water high pressure cleaner:
ignition "OFF" - Set thermostat with rotary control switch to 0 °C.
6. When using the machine as a hot water high pressure cleaner:
ignition "ON" - Set thermostat with rotary control switch to min. 40 °C
7. When using the machine as a hot water high pressure cleaner:
preselect the water temperature with thermostat to min. 40° C

High pressure hose and spray equipment

The high pressure hose and spray equipment supplied with the machine are made of high quality material specially adapted for the operating conditions of the machine, and are properly marked.



If spare parts are required, only properly marked components approved by the maker should be used. High pressure hoses and spray equipment must be connected so that they are pressure-tight. The high pressure hoses should not be driven over, pulled excessively or twisted. Do not pull the hose over sharp edges, since this will invalidate the warranty.

Commissioning

Commissioning

- Secure the machine by applying the brake.
- Open the right cover of the machine (without chimney) and check the oil level of the high pressure pump.
- Do not start the machine if there is no oil on the dipstick. Fill oil if necessary.

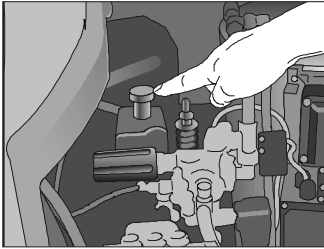
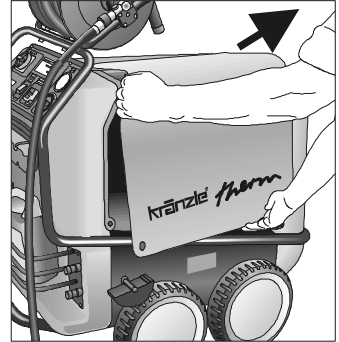

- Fill the fuel tank with light heating oil prior to use.



Use EL heating oil (DIN 51603) or diesel fuel only
Unsuitable fuels, such as petrol, may not be used (danger of explosion)

Water connection

Connect the machine to a water tap using a hose of at least 1/2" and turn on the tap. The water tank in the machine fills up. When the tank is full, the built-in float valve closes the water inlet.

Use clean water only!



Follow the instructions of the local water supply utility.
Connection of the machine to drinking water mains must be in accordance with DIN 1988.

High pressure connection

Connect the high pressure hose to the handgun.

Unwind the hose so that it is free of loops and connect it to the handgun and the machine.



Check that all screw-type connections are pressure-tight. Leaks from gun, high pressure hose or hose drum must be eliminated immediately. Leakage leads to increased wear.

Commissioning

Electrical connection

- Check that the master switch (1) is off (position "0").

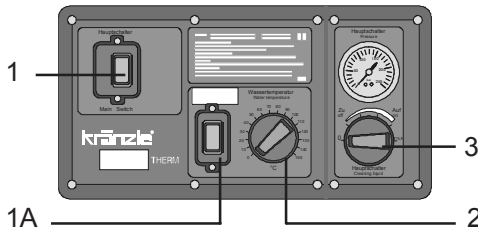

Connect the power cable to a properly installed electrical socket with earthing and a 30 mA FI fault current safety switch. The socket must have neutral 16A fusing on the mains side.

- Switch off the ignition. Rocker switch (1A) to „0“.
- Set the pressure control (4) valve to maximum pressure (see on page 12) and close the detergent valve (3).
- Open the gun and switch the master switch on.

The high pressure pump now presses the air out of the lines, and after a short time the high pressure spray forms and the operating pressure is reached. (Open and close the gun repeatedly)

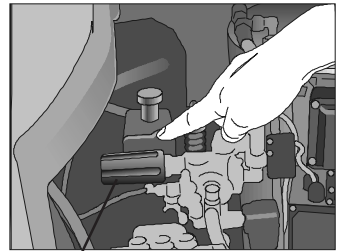

The machine is fitted with a Total-Stop-System. If the gun is closed for longer than approx. 20 seconds, the machine switches off automatically, after 20 minutes the machine moves to safety switch off and you must use the main switch to turn it back on. The machine restarts automatically when the gun is operated, provided that the master switch is on.



Usage as a cold water high pressure cleaner

- Leave the ignition "OFF". Rocker switch (1A) to „0“.
- Start cleaning

Usage as a hot water high pressure cleaner

- Set the target temperature on the thermostat to min. 40 °C and then switch the ignition "ON" (rocker switch). The oil burner starts to work. The water is heated up and kept at the temperature you have set.

Steam level

To reach the steam level, i.e. over 90 °C water temperature, open the right cover on the housing (see page 13) and adjust the pressure or water quantity on the hand wheel (4) downward and use the thermostat with rotary switch to select the temperature up to a maximum of 150 °. In the case of machines with hose drums, the high pressure hose must always be unwound completely.

Decommissioning

Usage with detergents

- The detergent must have the ph-value 7-9 neutral.
- Wait until the pump has pressed the air out of the lines
- Put the chemical filter into a container with detergent
- Open the detergent valve.
The pump now draws detergent in and mixes it with the high pressure spray.
- Set the desired concentration of detergent.
- At the end of the working procedure with detergent reset the rotary button to „O“.
- **When the high pressure cleaner is operated with open chemistry valve without chemicals, the pump sucks in air. Damages caused to the pump as a result are not covered by the guarantee.**

Comply with additive manufacturers' instructions (e.g. protective equipment and waste water regulations). Use only additives approved for use with high pressure cleaners. Using other additives impairs the safety of the machine.



In the interests of the environment and to keep expenditure down, we recommend sparing use of detergent. Please observe the recommendations of the detergent manufacturer. After using detergents, rinse the machine for approx. 2 minutes by pressing the trigger of the spray gun.

Adjusting the pressure

Use the pressure control valve (4) directly on the pump head to adjust the pressure.

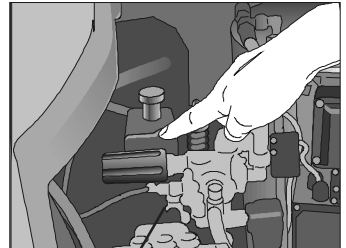

Decommissioning

- Switch off the master switch (position "0").
- Pull the plug out of the power socket.
- Turn off the water supply.
- Open the gun until the pressure is gone.
- Lock the gun.
- Disconnect the water hose.
- Slacken the connections of the high pressure hose and gun and unscrew the high pressure hose from the machine (appliances without hose drum).

Care and Maintenance

Anti-Freeze Protection

The machine is normally still partially filled with water after work has been completed. It is therefore necessary to take special precautions to protect the machine from frost.

- **Completely empty the machine of water.**

Disconnect the machine from the water supply and switch off the ignition. Switch on the master switch and open the gun. The pump now presses the remaining water out of the heating coil. Do not allow the machine to run for longer than a minute without water.

- **Fill the machine with anti-freeze**

If the machine is not in use for lengthy periods of time, it is advisable to pump anti-freeze into the machine, especially in winter. For this purpose, fill the anti-freeze agent into the water box and turn on the machine without ignition (rocker switch to „0“). Wait with opened gun, until the agent comes from the nozzle.

However, the best protection against frost is to keep the machine in a place that is safe from frost.

Care and Maintenance

Care and maintenance is required to keep the machine in good working order, and to allow you to enjoy the machine for as long as possible.



IMPORTANT!!!

Always remove the plug before working on the machine!

What to do!

- **Weekly, or after approx. 40 hours of operation**

- Check the oil level of the high pressure pump.

Loosen the red oil stopper on the high pressure pump and pull out the oil measuring rod.

If the oil level is too low, add oil until the oil level is between the two markings on the oil measuring rod.

Change the oil if it has a grey or whitish appearance. The oil should be disposed of responsibly.

- Check the filter in front of the float valve in the water tank and the fuel filter in front of the solenoid valve. Clean the filters if necessary.

- **Yearly, or after approx. 500 hours of operation**

- Desulphurise and decarbonize the heating coil.

- Check the oil burner and ignition system

Clean the oil nozzle, oil filter, solenoid valve and filter, clean and adjust the ignition transformer, ignition cable and ignition electrodes and replace defective parts

- Changing the oil

Care and Maintenance

Changing the oil

To do this, take the oil drainage hose (1) connected to the oil drain screw, from the inside of the machine and open the red oil filler cap on the top side of the black oil reservoir. Open the cap at the end of the hose. Drain off the oil into an oil pan and dispose of it responsibly. Close the end of the hose.

Refill with oil as described above.

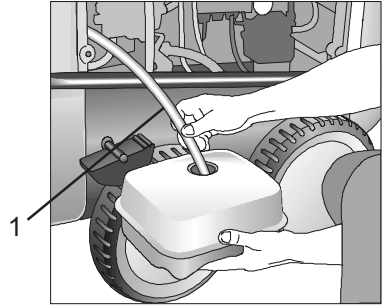

Oil leakage

If oil leaks out, go to the nearest customer service immediately (dealer). (Environmental damages, transmission damages, loss of guarantee.)



Type of oil: Formula RS of Castrol - Quantity: 1.0 l

Adjusting ignition electrodes

For a smooth ignition, the setting of the ignition electrode must be controlled regularly.

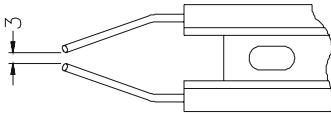

Check distance in mm

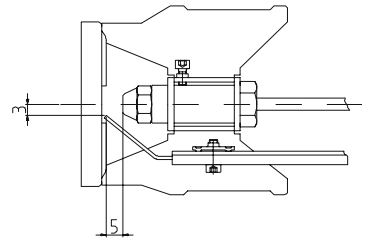

Fuel System

Your fuel may contain particles of dirt, or impurities or water may get into the tank during refuelling. Check the tank for impurities on a regular basis. Clean the tank when necessary

Empty the fuel tank using the drainage screw at the bottom of the tank. Clean the tank and fuel lines. Clean tank and fuel lines carefully and check to see whether there are water droplets on the inside of the tank, because these must be removed.



Detergent and dirty fuel must be disposed of responsibly.

Care and Maintenance

Decalcifying the heating coil

Calcified machines use an unnecessary amount of energy because the water can only be heated slowly and the excess pressure valve feeds a part of the water back into the pump circuit.

Calcified machines can be recognised by increased pipeline resistance.

Check pipeline resistance by disconnecting the high pressure lance from the gun and switching the machine on. A full jet of water emerges from the gun. The machine must be decalcified if the pressure shown on the manometer is greater than 25 bar.

Decalcifiers are caustic!



Observe the instructions for usage and accident prevention. Wear protective clothing to prevent the decalcifying agent from contacting your skin, eyes and clothing (eg, gloves, safety mask etc.)

Proceed as follows to decalcify the machine:

- Unscrew the high pressure hose from the machine and decalcify it separately.
- Put the detergent suction hose into a container of decalcifying solution.
- Set the dispenser valve to the maximum concentration.
- Switch on the machine.
- Hold the gun in a separate container and press the trigger.
- Wait for about a minute until the decalcifier comes out of the gun (recognisable by its whitish colour).
- Switch off the machine and allow the solution to act for about 15-20 minutes.
- Switch the machine back on and rinse it through with clear water for about 2 minutes.

Now check whether pipeline resistance is back to an acceptable level. Repeat the decalcifying process if the pressure without the high pressure lance is still above 25 bar.

Care and Maintenance

Rules, directives, inspections

● Inspections performed by Kränzle

- measurement of earth line resistance
- measurement of voltage and current
- inspection of tension consistency with +/- 1530 V
- pressure check of heating element at 300 bar
- visual and functional check as per the inspection sheet provided
- exhaust fume analysis (see test strips provided)

● Guidelines for liquid sprayers

The machine conforms with the "Guidelines for liquid sprayers". These guidelines are issued by the organisation of trade associations and may be obtained from Carl Heymann-Verlag KG, Luxemburger Str. 49, 50939 Köln. These guidelines specify that this machine is to be inspected by qualified personnel whenever necessary, but no less than once every 12 months. These inspections must be recorded in the inspection log at the end of this manual.

● Pressure container and steam boiler directives

Kränzle high pressure cleaning equipment conforms to the pressure container and steam boiler directive. No construction approval, notification of licence and takeover inspection are required. The water capacity is less than 10l.

● Duties of owner

The owner is to ensure before the sprayer is used that all safety-relevant components are in a serviceable condition. (e.g., safety valves, hose and electric cables, spray equipment etc).

● Emission control legislation

With stationary installation, the emission levels of the machine must be checked once a year by a qualified organisation or person according to German law. The first inspection must be carried out four weeks after the machine is commissioned. The owner is responsible for having the inspection performed.

Description of function - Troubleshooting



IMPORTANT!!!

Always remove the plug before working on the machine!

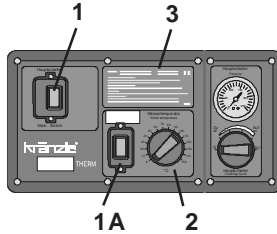

- 1 Master switch
- 1A Ignition "ON/OFF"
- 2 Thermostat with rotary switch
- 3 Brief operating instructions

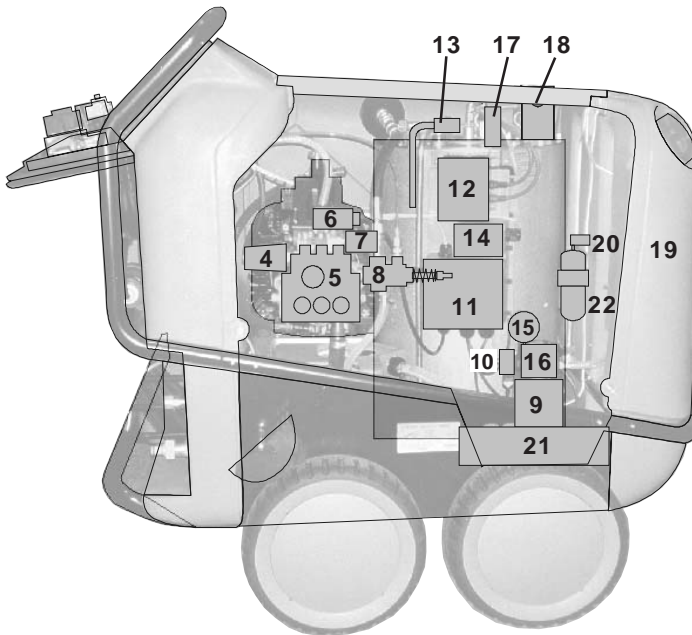

- 4 Hand wheel for pressure adjustment
- 5 High pressure pump
- 6 Pressure switch black (start solenoid valve)
- 7 Pressure switch red (start pump)
- 8 Safety valve
- 9 Motor for ventilator and fuel pump
- 10 Solenoid valve (Fuel)
- 11 Terminal box
- 12 Ignition transformer
- 13 Thermosensor water
- 14 Excess temperature release
- 15 Fuel manometer
- 16 Fuel pump
- 17 Ignition electrodes
- 18 Thermosensor exhaust gas
- 19 Fuel tank
- 20 Ball cock fuel
- 21 Ventilator
- 22 Fuel filter

Description of function - Troubleshooting

Cold water mode

1. Connect to water supply and determine whether the water tank fills up completely and the float valve stops.
2. Ignition (switch 1A) to OFF.
3. Main switch to ON.
4. Open high pressure gun. The pump sucks water from the water tank and moves the water through the heating coil to the lance, the pressure is increased.

After you close the gun, press the red pressure switch (7). The 20-Second-Stop system is activated, i.e. after closing the gun, the pump motor is turned off after 20 seconds. When you open the gun the motor starts again.

If the gun stays closed for more than 20 minutes, the safety switch off is activated and the machine is turned off completely, i.e. if you want to use the machine you must first turn it OFF and then ON with the main switch.



ATTENTION!!

If the pressure is not built up immediately, there is still air in the pump. Open and close the gun repeatedly to press the air from the machine.

Hot water mode

Start the machine just like in cold water mode and then turn the rocker switch for the burner to ON. Then, turn the rotary switch on the thermostat, (2) located on the front, to the desired temperature (at least 40 °C) in order to activate the burner, i.e., that fuel is injected.

The manometer (15) on the fuel pump shows approx. 10 bars. If this display is missing, check whether

1. there is heating oil in the tank
2. the fuse in the terminal box (11) for the motor (9) has blown.
3. the fuel sieve (22) or the fuel sieve in the pump (16) is dirty.
4. the ball cock (20) is closed.
5. the fuel pump does not operate smoothly or is blocked.
6. the ventilator jams.

The thermostat grants permission to open the solenoid valve; after opening the gun, the burner starts. If the solenoid valve is open, the fuel pressure is approx. 10 bars. The burner starts and heats the water to the temperature preset by you. When the temperature is reached, the burner turns off. If the temperature drops again, the burner switches back on automatically, so that you continuously have the desired temperature.

Description of function - Troubleshooting

The thermostat with rotary switch is controlled by a thermosensor, mounted to the outlet of the heating coil.

In the electro distributor box (11) mounted to the combustion unit, there is a fuse, which protects the motor (9) for the fuel pump and ventilator. If the motor is overloaded, the fuse blows. This can happen when the fuel pump is blocked or does not work freely, when the ventilator is blocked or does not operate freely or when there is an electrical problem.

There is a thermosensor (18) in the waste gas tube, which controls an excess temperature relay with trigger function (4), i.e. when the exhaust gas temperature in the chimney increases above 230 °C, this relay triggers. To activate it again, you must wait until the combustion unit has cooled, i.e. approximately 15 minutes. Then, you can press the button under the cover (14) again. The excess temperature relay can trigger when the machine is operated over a longer period in the highest steam level, or when there is lots of soot on the heating coil due to poor combustion, or when the inside of the heating coil is calcified, so that there is no ventilation (cooling).

As further safety function, the burner is also switched off, when the water temperature exceeds 147 °C.

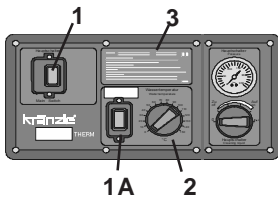

- 1 Master switch
- 1A Ignition "ON/OFF"
- 2 Thermostat with rotary switch
- 3 Brief operat. instruction
- 4 Hand wheel for pressure adjustment
- 5 High pressure pump
- 6 Pressure switch black
- 7 Pressure switch red
- 8 Safety valve
- 9 Motor for ventilator and fuel pump
- 10 Solenoid valve (Fuel)
- 11 Terminal box
- 12 Ignition transformer
- 13 Thermosensor water
- 14 Excess temperature release
- 15 Fuel manometer
- 16 Fuel pump
- 17 Ignition electrodes
- 18 Thermosensor exhaust gas
- 19 Fuel tank
- 20 Ball cock fuel
- 21 Ventilator
- 22 Fuel filter

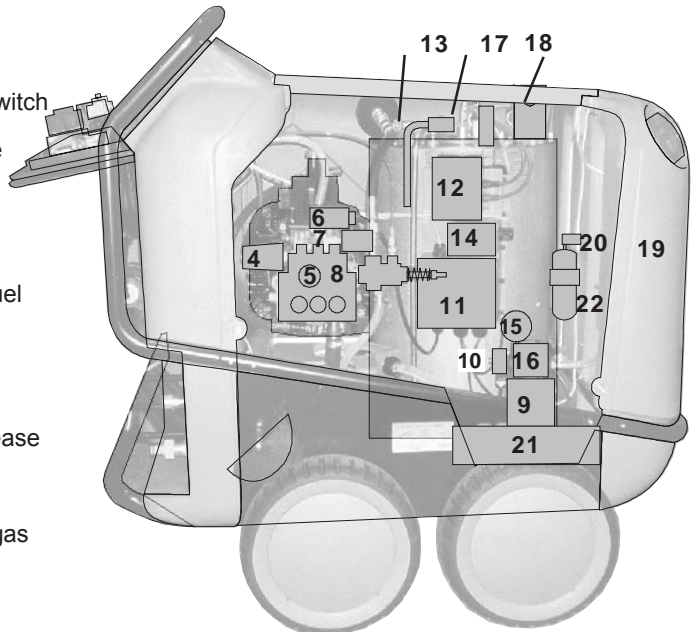

Troubleshooting



IMPORTANT!!!

Always remove the plug before working on the machine!

<i>Malfunction</i>	<i>Cause of malfunction / Trouble shooting</i>
<p>Water supply</p> <p>Water tank runs over.</p> <p>Water tank does not fill completely.</p> <p>Pump does not suck.</p> <p>Test: check water and chemical system for tightness.</p>	<p>Float valve is dirty. Float valve is defect.</p> <p>Water filter is dirty. Check water inlet quantity.</p> <p>Valves stick or are dirty. Suction hose leaks.</p> <p>Chemistry valve is open or leaks.</p> <p>Check hose clips (connections). High-pressure nozzle is clogged.</p> <p>Connect water inlet directly to the pump (2-4 bar pre-pressure).</p>
<p>High-pressure pump</p> <p>Pump makes lots of noise. Operating pressure is not reached.</p> <p>Water drops from the pump.</p> <p>Oil drops from the transmission.</p> <p>Pressure is too low</p>	<p>Pump sucks air. Check suction connections. Check high-pressure nozzle. Check valves. Check O-rings under valves. Check sleeves. Manometer is defect. Unloader: check stainless steel seat and ball. Check seals on the control piston.</p> <p>Replace sleeves in the pump. Replace O-rings.</p> <p>Check oil seals (replace). Check plunger and plunger guides. Check water supply, since water deficiency or air suction can cause damage to seals and O-rings (chemistry valve leaks?).</p> <p>Worn high pressure nozzle</p> <p>Stainless steel seat, ball, O-ring in unloader is dirty or defect.</p> <p>Manometer is defect</p>
<p>Machine does not switch off</p> <p>Test: Disconnect pressure switch (red) bridge on the panel between terminal 5 + 6</p>	<p>Check return body and O-ring in unloader of the valve housing.</p> <p>Check pressure switch (red). Check micro switch.</p> <p>Check cable connections.</p> <p>Board is defect.</p>

Troubleshooting

<i>Malfunction</i>	<i>Cause of malfunction / Trouble shooting</i>
Machine does not start	<p>Check electricity supply.</p> <p>Check main switch. Check cable connections.</p> <p>Check board. Check pressure switch.</p> <p>Switch off by overcurrent release.</p>
<p>Heating (burner)</p> <p>Fuel pump/blower operates, but burner does not heat.</p> <p>Fuel pump/blower does not operate. - Pump makes lots of noise - Fuel operating pressure has not been reached</p> <p>Coupling between burner motor and fuel pump is broken</p> <p>Solenoid valve on the fuel pump does not open Test: Pressure switch (black) Bridge in terminal box between terminal 3 +4 Test: Connect solenoid valve 230 V externally Oil pressure on the fuel pump is too low too high</p>	<p>Set water temperature is reached. Increase temperature on thermostat with rotary control switch. Open gun, until temperature drops.</p> <p>Fuel tank is empty. Fuel filter is dirty. Fuel nozzle is dirty. Float switch in fuel tank is defect.</p> <p>Blower/fuel pump motor is defect. Check electrical equipment.</p> <p>Check fuse in terminal box. Coupling between burner motor and fuel pump is defect.</p> <p>Water in fuel tank. Dirt or rust in the fuel pump. Clean tank. Replace fuel pump.</p> <p>Check pressure switch (black). Solenoid valve is defect or dirty.</p> <p>Clean filter, clean supply line, clean fuel pump. Setting is wrong.</p> <p>Clean fuel nozzle, or replace it.</p>

Troubleshooting

<i>Malfunction</i>	<i>Cause of malfunction / Trouble shooting</i>
Ignition does not function	<p>Check ignition cable.</p> <p>Charring of plug-in contacts by moisture. Cable is broken</p> <p>Check ignition transformer connections.</p> <p>Transformer is defect</p> <p>Ignition electrode has been falsely set or burnt up.</p>
Ventilator does not operate	<p>Blower-/fuel pump motor is defect. Check electrical equipment.</p> <p>Check fuse in terminal box. Coupling between burner motor and fuel pump is defect.</p>
Burning Smoke during operation Smoke after switching off	<p>Fuel is dirty.</p> <p>Nozzle or nozzle stock leaks. Water in tank.</p>
Spray gun - High-pressure hose Gun drips High pressure hose drips Nozzle is clogged	<p>Check for leakages.</p> <p>Replace seals.</p> <p>Replace O-ring under screwed connection.</p> <p>Manometer indicates pressure, but no water comes out of HP-hose – clean nozzle.</p>
Sucking detergent Detergent is not sucked	<p>Pump sucks air. Check hose clips.</p> <p>Test: Connect water line to the pump. Water inlet: 2 - 4 bar pre-pressure. No water must come from the detergent hose.</p>

Guarantee

Warranty

This warranty covers material and/or workmanship related defects only and does not extend to ordinary wear.

Machine must be operated according to enclosed operating instructions which are part of present warranty conditions.

All products sold directly to private customers are warranted for a period of 24 months, whereas the warranty period for industrial purchases is limited to 12 months.

In case of any warranty claims, please have your HP cleaner together with accessories and your purchase document ready and contact your nearest dealer or authorized service point which can also be looked up in the internet at www.kraenzle.com.

Warranty is void in case of attempts to modify any of the safety devices or in the event of exceeding temperature or rpm limits - this also applies to undervoltage, low water and/or polluted water. Gauge, nozzle, valves, sealing gaskets, high pressure hose and spray equipment are considered wear parts and do not fall under this warranty.

Circuit diagramme

- A1 Ignition transformer
- B1 Thermostat
- F1 Fuse 3.15 timelag
- K3 Motor contactor
- M1 Motor, HP pump
- M2 Combustion motor
- Q1 Master switch
- Q2 Burner switch
- S1 Excess temperature trigger
- S2 Differential pressure switch
- S3 Press switch burner release
- S4 Float switch (Fuel)
- S5 Waterflow detector
- Y1 Fuel valve

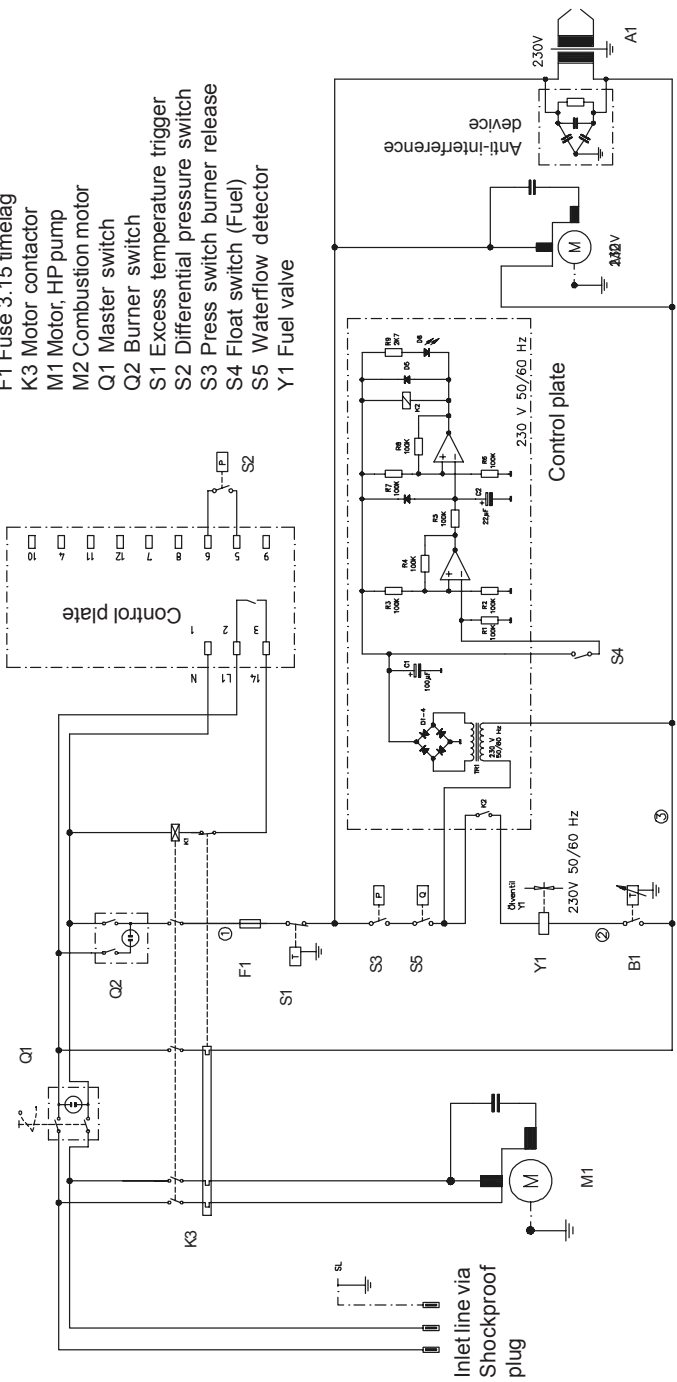

Terminal box terminal plan

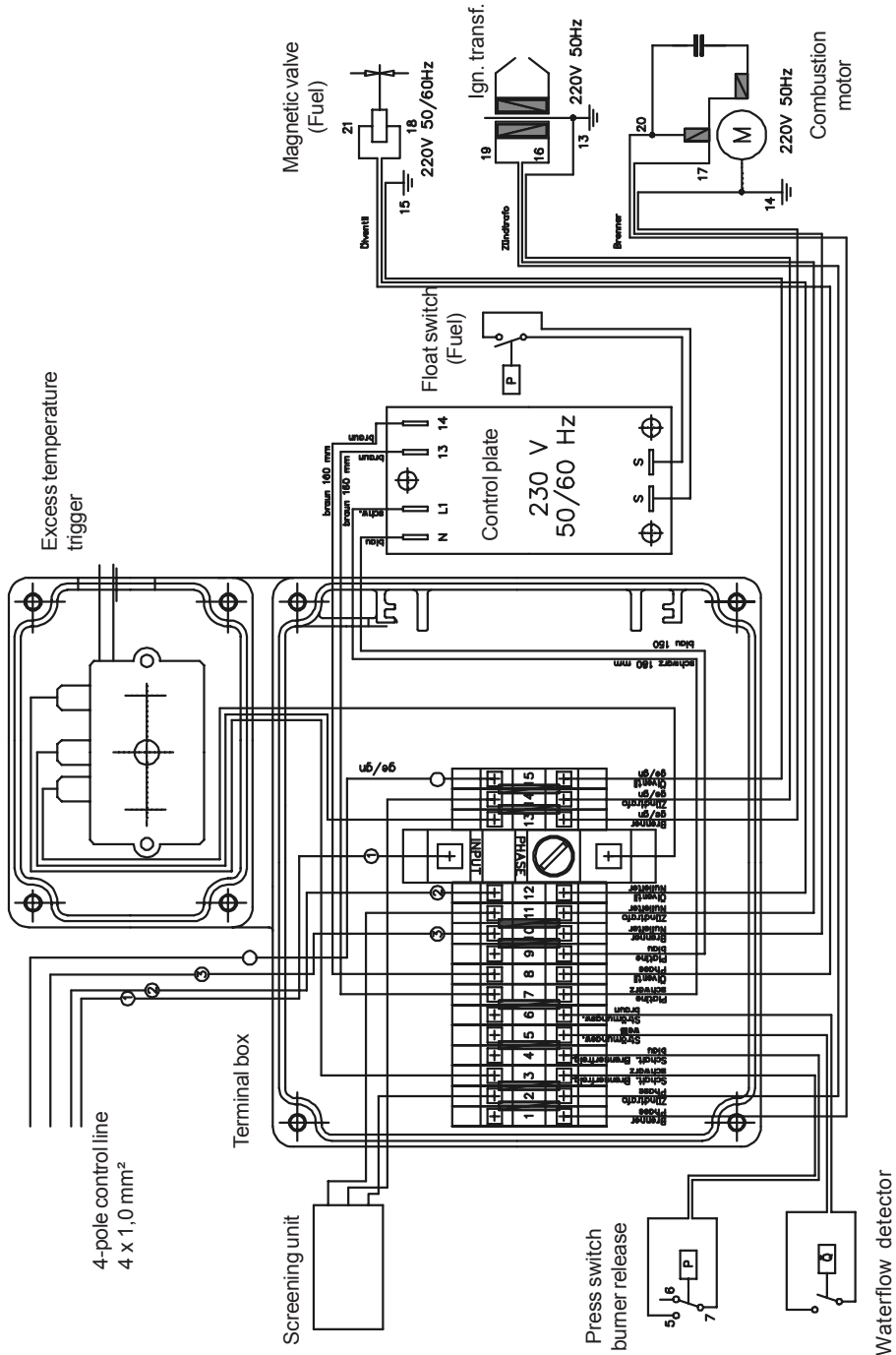

Cockpit terminal plan

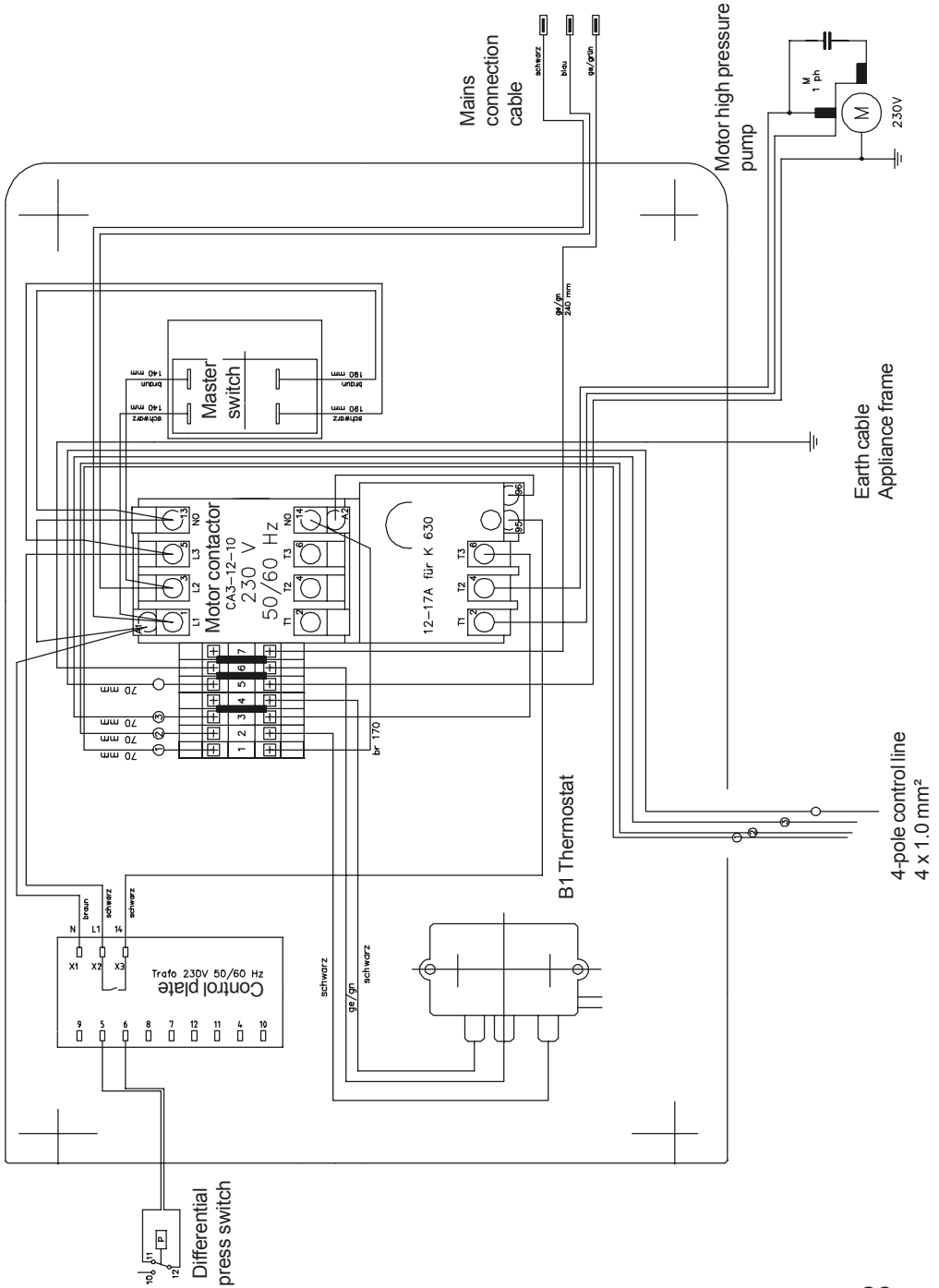

Complete Assembly

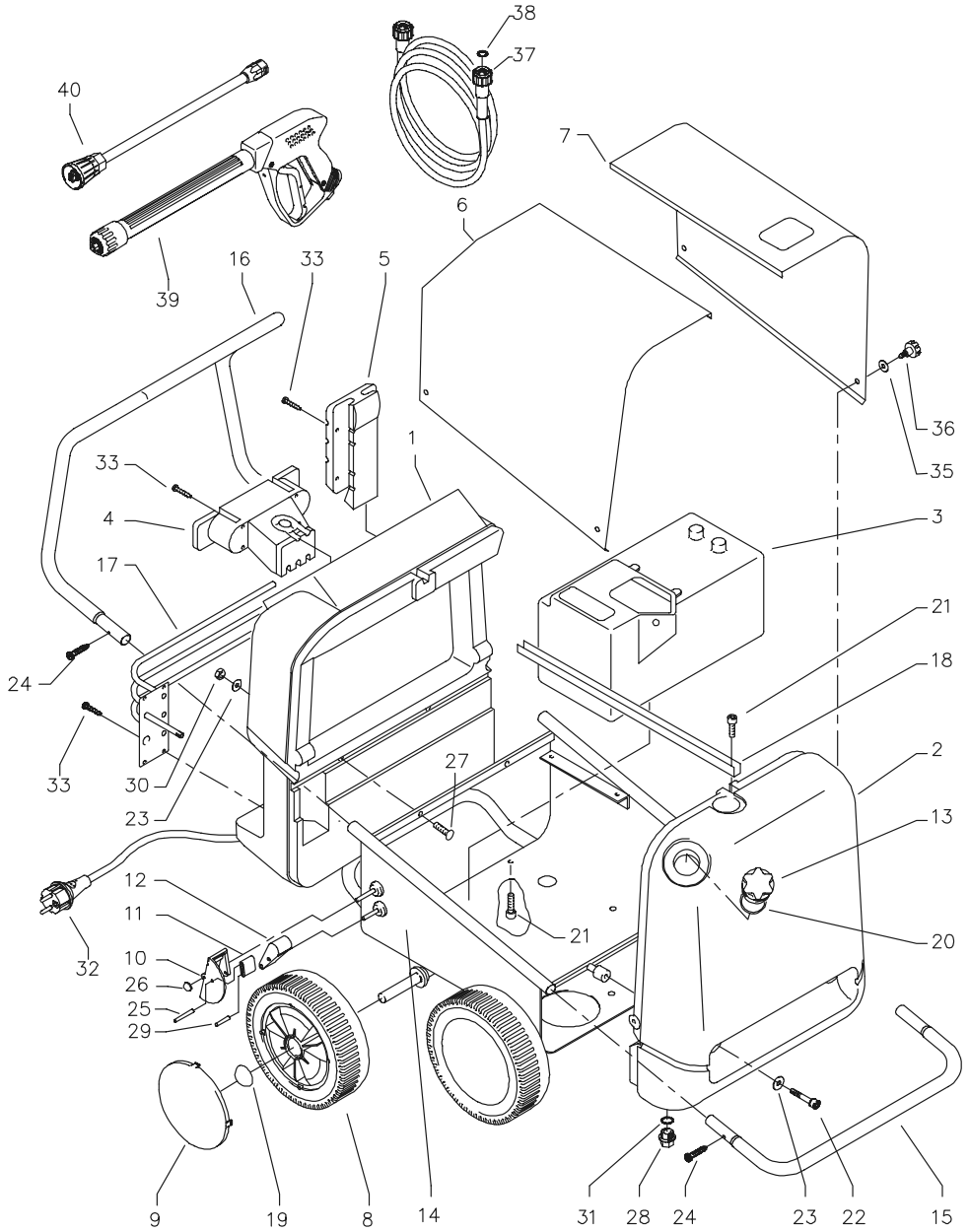

Kränzle therm 630

No.	Description	Qty.	Order No.
1	Cockpit	1	44.006
2	Brennstofftank	1	44.004
3	Wassertank	1	44.009
4	Kabelaufwicklung	1	44.007
5	Lanzenköcher	1	44.008
6	Haube rechts	1	44.032
7	Haube links	1	44.031
8	Rad	4	44.017
9	Radkappe	4	44.018
10	Bremspedal	1	44.022
11	Bremshebel	1	44.023
12	Bremsklotz	1	44.024
13	Tankdeckel	1	44.005
14	Fahrgestell	1	44.001
15	Frontbügel	1	44.002
16	Schubbügel	1	44.003
17	Reeling	1	44.016
18	Top-Strebe	1	44.019
19	Starlock-kappe 20 mm	4	40.142
20	O-Ring 70 x 5	1	44.020
21	Innensechskantschraube M 8 x 12	4	40.122
22	Innensechskantschraube M 8 x 35	2	41.510
23	Unterlegscheibe 8,4 DIN 9021	4	41.409
24	Schraube 3,9 x 16	4	12.150
25	Stift 6 x 50	1	44.035
26	Starlockkappe 8 mm	1	44.165
27	Schlossschraube M 8 x 35	2	41.408
28	Ablassschraube Brennstofftank	1	44.004 1
29	Stift 6 x 40	1	44.035 1
30	Elastic-Stop-Mutter M 8	2	41.410
31	Dichtung für Ablassschraube	1	41.047 1
32	Netzanschlussleitung mit Stecker 5,75m, 3x 1,5 mm ² , H07RNF	1	41.092
33	Kunststoffschraube 6 x 30	12	43.423 1
35	Scheibe	4	44.034
36	Sterngriff	4	50.168 1
37	Hochdruckschlauch NW 8 20 m	1	41.083 3
37.1	Hochdruckschlauch NW 8 10 m	1	41.081 3
38	O-Ring 9,3 x 2,4 Viton	2	13.273 1
39	Pistole mit Verlängerung - Starlett II	1	12.320 2
40	Lanze mit Flachstrahldüse	1	12.392 2-25045

Electronics switchbox

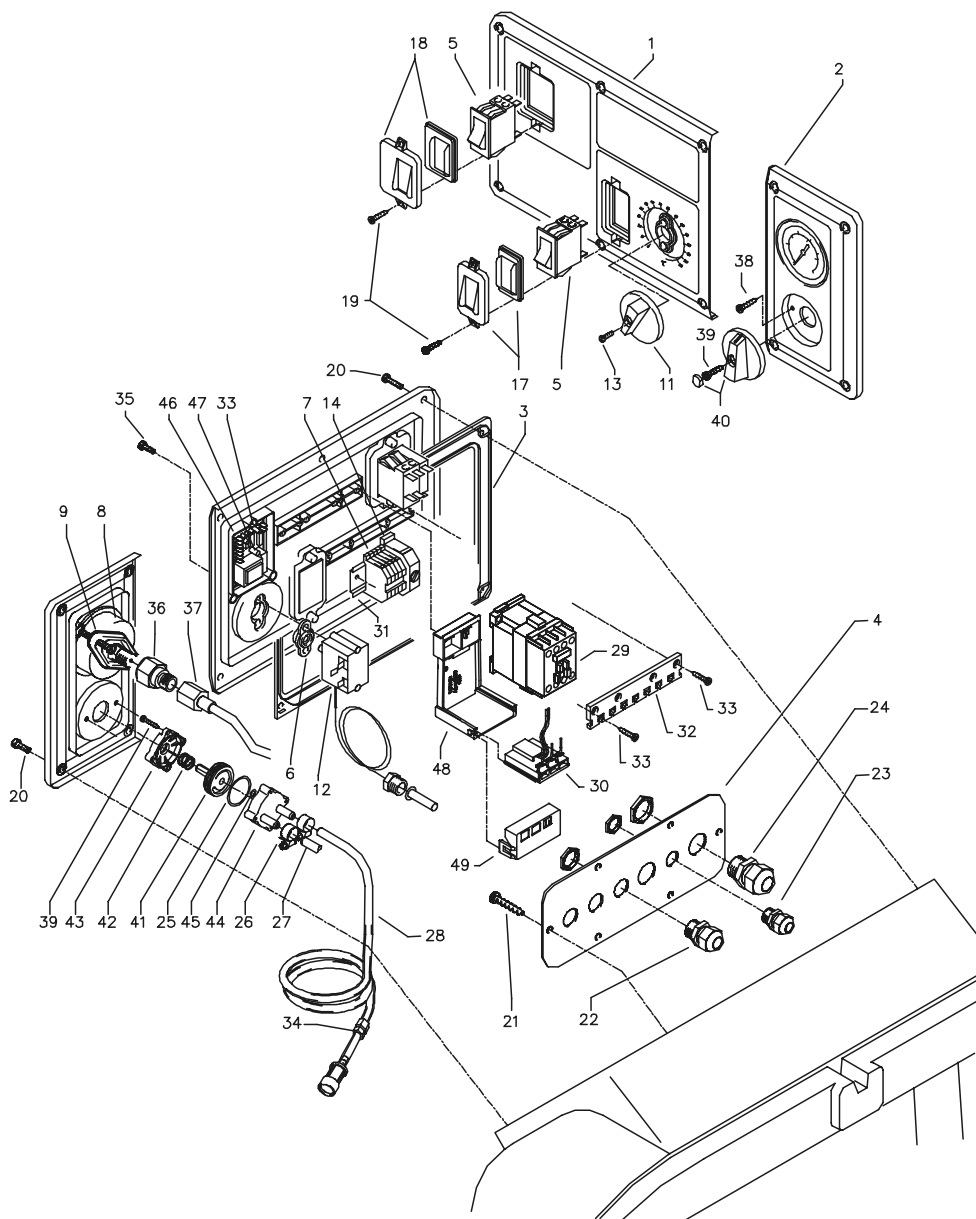

Kränzle therm 630

No.	Description	Qty.	Order No.
1	Frontplatte Elektrik 630	1	44.158 2
2	Frontplatte Manometer	1	44.043
3	Gummidichtung Elektrik	1	44.044
4	Kabeldurchführungsplatte	1	44.045
5	Hauptschalter	1	41.111 6
6	Dichtung für Thermostat	1	44.156
7	Klemme Wago 2,5 mm ²	1	44.047
7.1	Erdungsklemme Wago 2,5 mm ²	1	44.048
8	Manometer	1	15.039 1
9	Klemmbügel für Manometer	1	44.049
11	Drehgriff Thermostat	1	44.153
12	Thermostat drehbar 0-150°C	1	44.167
13	Gewindeschneidschraube M 2,5 x 8	1	44.168
14	Klemmsockel mit Sicherung 3,15 A träge	1	44.166
14.1	Feinsicherung 3,15 A träge	1	44.166 3
16	Abdeckkappe Übertemperaturauslöser	1	44.154
18	Klemmrahmen mit Schalterabdichtung	1	43.453
19	Kunststoffschraube 3,5 x 9,5	4	41.088
20	Schraube M 5 x 10	10	43.021
21	Kunststoffschraube 5,0 x 14	6	43.426
22	PG-Verschraubung PG 11	3	41.419
23	PG-Verschraubung PG 9	1	41.087
24	PG-Verschraubung PG 16	2	41.419 1
25	O-Ring 28,24 x 2,62	1	44.149
26	Schlauchklemme 9 - 9	2	44.054
27	Kunststoffschlauch für Waschmittelansaugung	1	44.055
28	Kunststoffschlauch mit Filter	1	44.056
29	Motorschütz CA3-12-10 230 V 50/60 Hz	1	44.057 1
30	Überstromauslöser CT3- 12-17,5 A	1	44.058 2
31	Hutschiene 125 mm lang	1	44.125
32	Kabelhalteschiene	1	44.155
33	Blechschrabe 3,9 x 9,5	11	41.636
35	Schraube M 4 x 12	2	41.089 1
36	Anschlussmuffe Manometer	1	44.136
37	Druckmessleitung	1	44.102
38	Blechschrabe 3,5 x 19	2	44.162
39	Blechschrabe 3,5 x 16	3	44.161
40	Drehgriff Chemieventil mit Blendkappe	1	44.151
41	Regulierkolben Chemieventil	1	44.147
42	Edelstahlfeder 1,8 x 15 x 15	1	44.148
43	Deckel für Chemieventil	1	44.146
44	Gehäuse Waschmittelventil	1	44.145
45	O-Ring 5 x 1,5 (Viton)	1	44.150
46	Klemmrahmen für Platine Nachlaufverzögerung	1	44.194
47	Platine Nachlaufverzögerung 230 V / 50/60 Hz	1	42.504
	Chemieventil kpl. Pos. 25-27, 39-45		44.052

Water supply

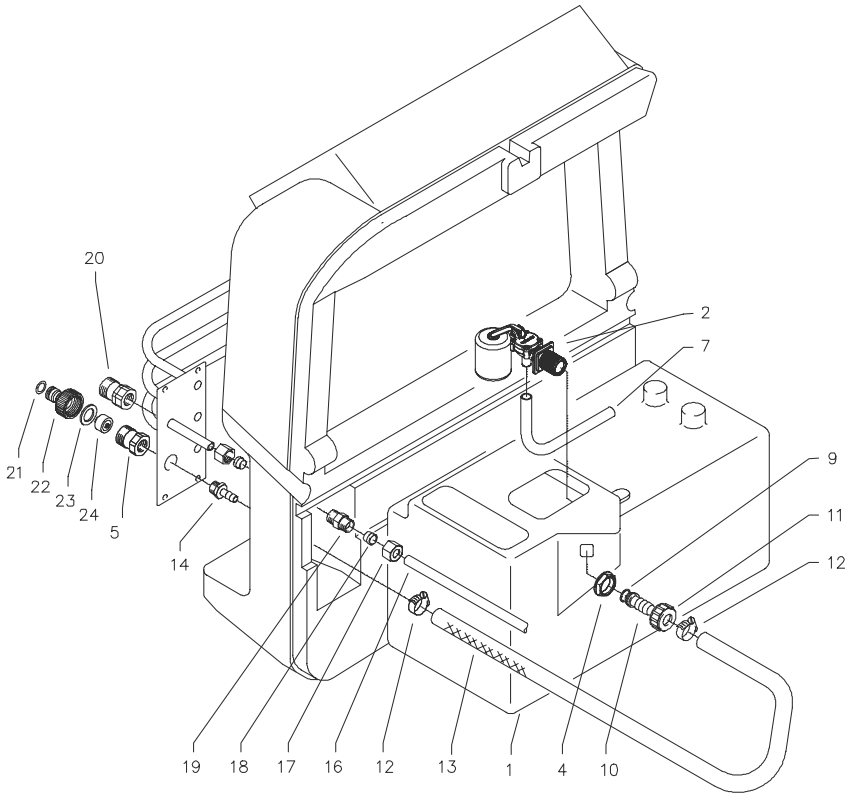

No.	Description	Qty.	Order No.
1	Wassertank	1	44.009
2	Schwimmerventil	1	46.250 5
5	Anschlußstück R 3/8" IG	1	41.423
7	Einströmschlauch	1	44.027
9	O-Ring 13 x 2,6	1	13.272
10	Schlauchtülle	1	44.126
11	Überwurfmutter	1	41.047
12	Schlauchschelle 12 - 22	2	44.054 2
13	Wassereingangsschlauch	1	44.028
14	Schlauchtülle R3/8" x 13	1	44.029
16	Ermetrohr 12 mm	1	44.030
17	Ermetmutter 12 mm	2	40.075
18	Klemmhülse 12 mm	2	40.074
19	Ermetverschraubung 12 L x 12 L	1	44.060
20	Wasserausgangsteil	1	44.061
21	O-Ring	1	41.047 3
22	Steckkupplung	1	41.047 2
23	Gummidichtung	1	41.047 1
24	Wasserfilter	1	41.046 2
	Steckkupplung kpl. Pos. 21-23		41.047 4

Fuel supply

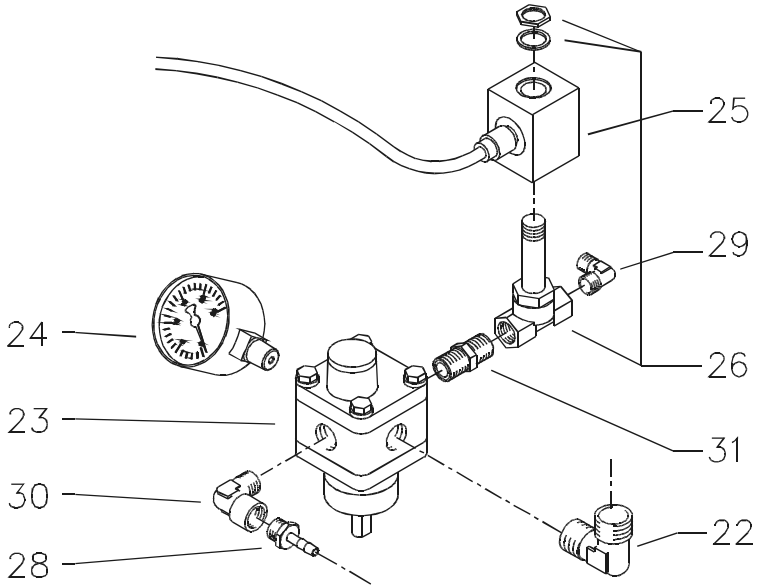

Pos.	Bezeichnung	Stck	Best.Nr.
22	Einschraubwinkel R1/4" AG x 10L	2	40.121 1
23	Brennstoffpumpe mit Magnetventil	1	44.073
24	Brennstoffmanometer 0-15 bar R1/8"	1	44.082
25	Magnet für Magnetventil	1	44.251 1
26	Magnetventil	1	44.251
28	Schlauchtülle 1/4" x 6	1	44.053
29	Winkeleinschraubverschraubung 1/8" x 6	1	44.110 1
30	Winkeleinschraubverschraubung 1/4" AG x 1/4" IG	1	40.121
31	Doppelnippel 1/4" x 1/4"	1	44.251 2
Brennstoffpumpe kpl. Pos. 22-26, 28-31			44.073 1

Heat exchanger

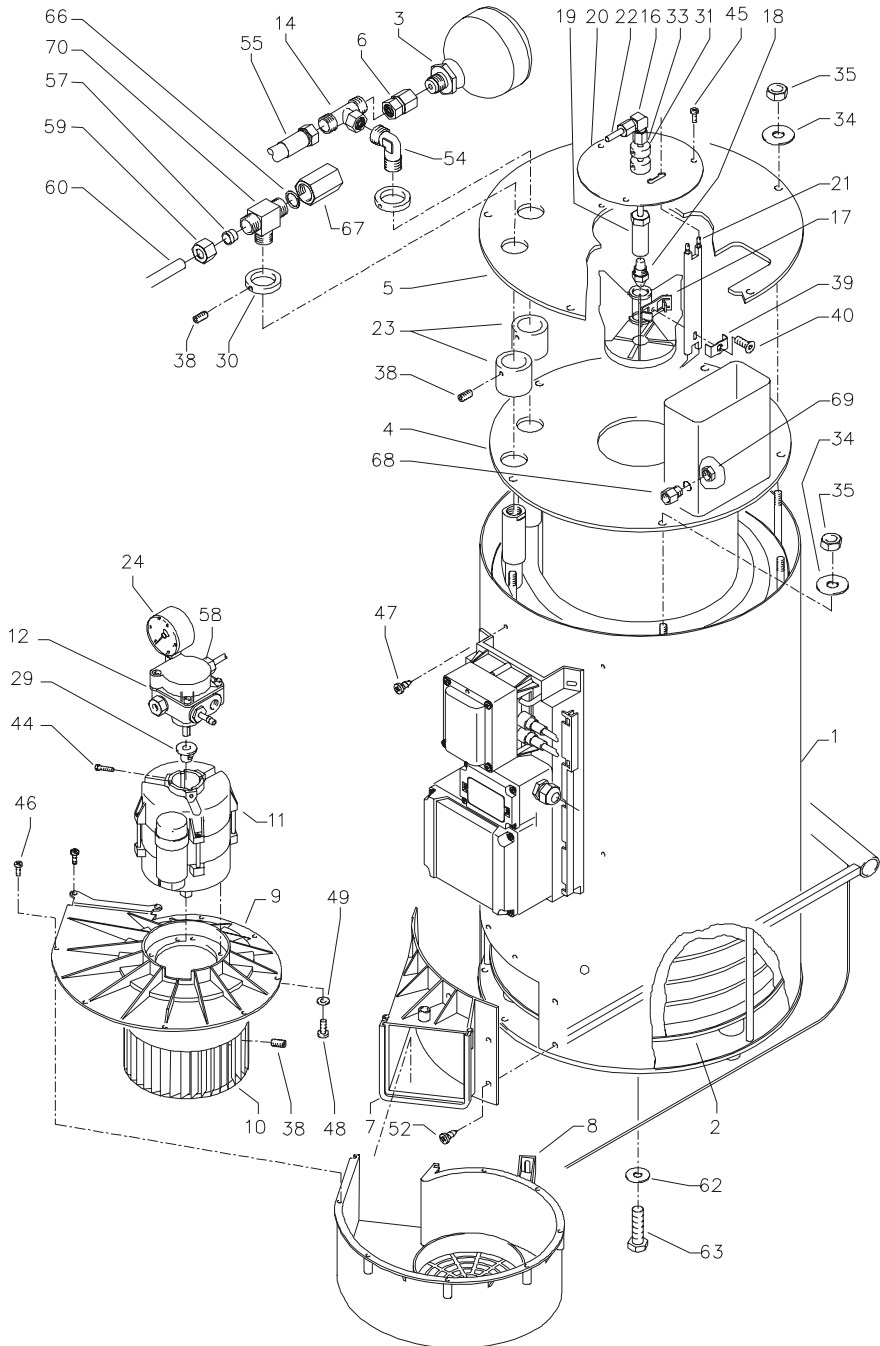

Kränzle therm 630

No.	Description	Qty.	Order No.
1	Außenmantel	1	44.063
2	Heizschlange mit Innenmantel	1	44.064
3	Hydrospeicher	1	44.140
4	Innendeckel	1	44.065
5	Außendeckel	1	44.066
6	Anschlußmuffe für Hydrospeicher	1	44.140 1
7	Gebläsestutzen	1	44.068
8	Gebläsegehäuse	1	44.069
9	Gebläsedeckel	1	44.070
10	Lüfterrad	1	44.071
11	Brennermotor 220 V / 50 Hz	1	44.072
11.1	Brennermotor 220 V / 60 Hz	1	44.072 1
12	Brennstoffpumpe mit Magnetventil	1	44.073
14	Einstellbare T-Verschraubung	1	44.141
16	Winkelverschraubung 6L x 6L	1	44.106
17	Düsenstock	1	44.076
18	Brennstoffdüse 60° B Ø1,25	1	44.077 1
19	Düsenhalter	1	44.078
20	Deckel Düsenstock	1	44.079
21	Blockelektrode	1	44.080
22	Brennstoffleitung Pumpe	1	44.108
23	Abschlußhülse	2	44.081
24	Brennstoffmanometer 0 - 15 bar R 1/8"	1	44.082
29	Steckkupplung	1	44.085
30	Abschlußring	2	44.086
31	Tiefenanschlag	1	44.088
33	Brennstoffleitung „Düsenstock“ 137 mm	1	44.089
34	Scheibe 8,4 DIN125	7	50.186
35	Mutter M 8	7	14.127
36	Ringmutter M 8 DIN 582	3	44.115
38	Gewindestift M 6 x 8 DIN 914	7	44.090
39	Klemmblech für Elektrode	1	44.076 1
40	Zyl.schraube mit ISK M 5 x 15 DIN6912	1	44.076 2
44	Zyl.schraube mit ISK M 5 x 12 DIN 912	1	40.134
45	Schraube M 6 x 12	3	43.421
46	Kunststoffschraube 5,0 x 20	9	50.157
47	Blechschaube 4,8 x 13	4	44.112
48	Schraube M 4 x 10	4	44.091
49	Unterlegscheibe 4,3	4	44.059
52	Blechschaube 6,3 x 13	7	44.109
54	Einschraubwinkelversch. 3/8" x 12L	2	44.092
55	Hochdruckschlauch	1	44.093
57	Schneidring 12 mm	1	40.074
58	Winkeleinschraubverschraubung 1/8" x 6	1	44.110 1
59	Überwurfmutter f. Ermeto 12 mm	1	40.075
60	Ermetorohr	1	44.030
62	Unterlegscheibe A 10,5 DIN 9021	3	50.182
63	Sechskantschraube M 10 x 20 DIN 933	3	44.116
64	Federring A 10 DIN 127	3	44.116 1
66	Dichtring	1	14.149
67	Fühleraufnahme	1	44.170
68	Fühler Muffe	1	44.171
69	Mutter	1	44.172
70	Einschraub-T R3/8" x 2x 12 mm	1	44.173

Unloader and pressure switch

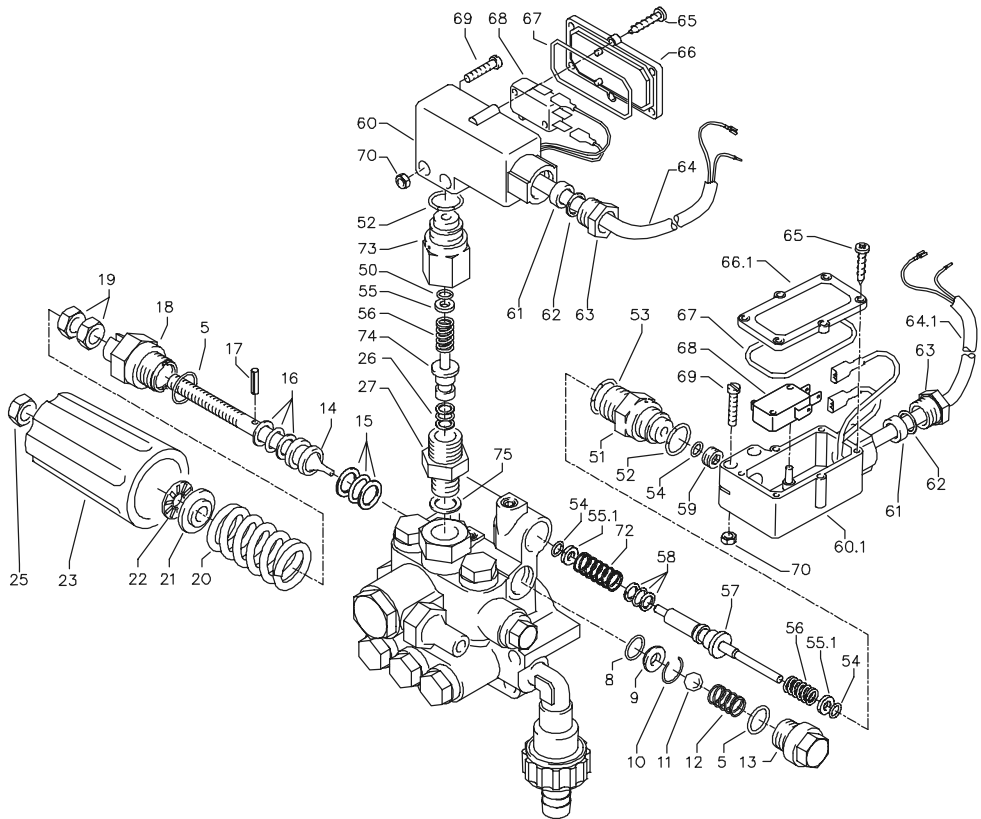

No.	Description	Qty.	Order No.
	Ventilgehäuse kpl. mit Druckschaltermechanik, Pos. 5-59, 73, 74		42.160 2
	Steuerkolben kpl. Pos. 5, 14-25		14.132 2
	Druckschalter (schwarz) kpl. mit Kabel 0,59 m Pos. 26, 27, 52, 54, 55, 56, 60 - 74		44.120
	Druckschalter (rot) kpl. mit Kabel 0,49 m Pos. 51 - 74		44.120 2
	Ausgangsstück für Schalter rot kpl. Pos. 51 -59		15.009 3
	Ausgangsstück für Schalter schwarz kpl. Pos. 26, 27, 52, 54-56, 73, 74		15.011 1

Kränzle therm 630

No.	Description	Qty.	Order No.
5	O-Ring 16 x 2	2	13.150
8	O-Ring 11 x 1,44	1	12.256
9	Edelstahlsitz	1	14.118
10	Sicherungsring	1	13.147
11	Edelstahlkugel 8,5 mm	1	13.148
12	Edelstahlfeder	1	14.119
13	Verschlusschraube	1	14.113
14	Steuerkolben	1	14.134
15	Parbaks 16 mm	1	13.159
16	Parbaks 8 mm	1	14.123
17	Spannstift	1	14.148
18	Kolbenführung spezial	1	42.105
19	Mutter M 8 x 1	2	14.144
20	Ventilfeder schwarz	1	14.125
21	Federdruckscheibe	1	14.126
22	Nadellager	1	14.146
23	Handrad	1	14.147
25	Elastic-Stop-Mutter	1	14.152
26	Parbaks 7 mm	1	15.013
27	Ausgangsteil R1/4" AG	1	15.011
50	O-Ring 5 x 1,5	1	15.014
51	Führungsteil Steuerstößel	1	15.009 1
52	O-Ring 12,3 x 2,4	2	15.017
53	O-Ring 14 x 2	1	43.445
54	O-Ring 3,3 x 2,4	4	12.136
55	Stützscheibe dm 5	1	15.015
55.1	Stützscheibe dm 4	2	15.015 1
56	Edelstahlfeder	2	15.016
57	Steuerstößel lang	1	15.010 2
58	Parbaks	1	15.013
59	Stopfen M10x1 (durchgebohrt)	1	13.385 1
60	Gehäuse Elektroschalter (schwarz)	1	15.007
60.1	Gehäuse Elektroschalter (rot)	1	15.007 1
61	Gummimanschette PG 9	2	15.020
62	Scheibe PG 9	2	15.021
63	Verschraubung PG 9	2	15.022
64	Kabel 3 x 1,0 mm ² 0,59 m	1	44.131
64.1	Kabel 3 x 1,0 mm ² 0,49 m	1	44.131 1
65	Blechschrabe 2,9 x 19	12	15.024
66	Deckel Elektroschalter (schwarz)	1	15.008
66.1	Deckel Elektroschalter (rot)	1	15.008 1
67	O-Ring 44 x 2,5	1	15.023
68	Mikroschalter	1	15.018
69	Zylinderschraube M 4 x 20	4	15.025
70	Sechskant-Mutter M 4	4	15.026
73	Grundteil Elektroschalter	1	15.009
74	Steuerkolben	1	15.010

Terminal box and transformer

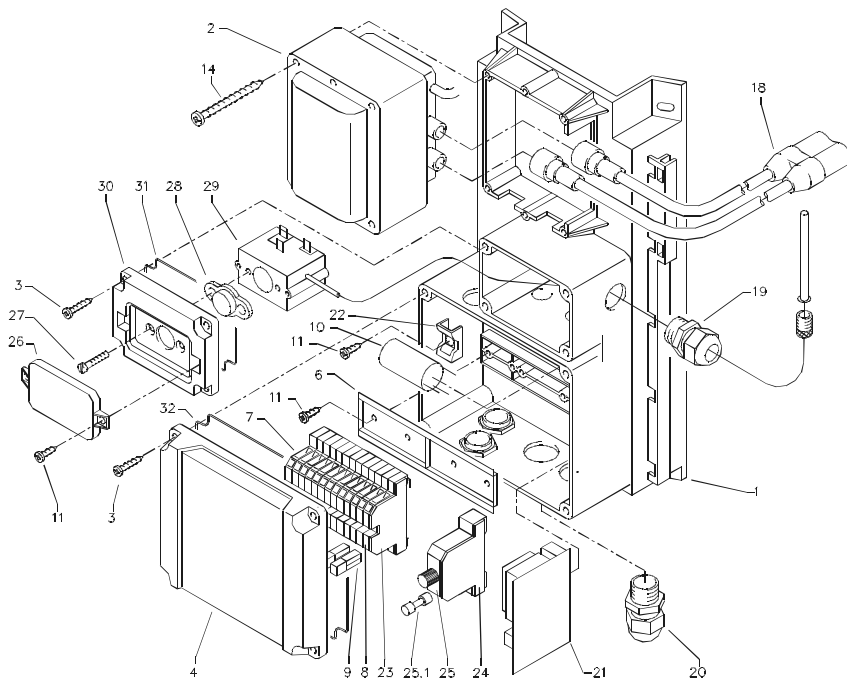

No.	Description	Qty.	Order No.
1	Konsole mit integr. Klemmkasten	1	44.067 1
2	Transformator 230 V / 50 Hz	1	44.074
3	Kunststoffschraube 4,0 x 25	8	43.425
4	Deckel für Klemmkasten	1	44.075 2
6	Hutschiene für Verteilerkasten	1	44.125
7	Durchgangsklemme grau	18	44.047
8	Durchgangsklemme grün/gelb	3	44.048
9	Querbrücker 24 A	6	44.047 1
10	Entstörkondensator	1	44.124
11	Blehschraube 3,9 x 9,5	7	12.172
14	Kunststoffschraube 4 x 60	4	43.420
18	Zündkabel mit Stecker	1	44.114
19	PG-Verschraubung PG 16	2	41.419 1
20	PG-Verschraubung PG 11	5	41.419
21	Steuerplatine für Ölabschaltung 230V / 50Hz	1	44.302
22	Haltesockel für Entstörglied	1	44.178
23	Abdeckplatte für Durchgangsklemme	1	44.047 2
24	Abdeckplatte für Sicherungsklemme	1	44.166 1
25	Halteklemme für Feinsicherung	1	44.166
25.1	Feinsicherung 3,15 A träge	1	44.166 3
26	Abdeckkappe Überstromauslöser	1	44.154
27	Schraube M 4 x 12	2	41.089 1
28	Dichtung für Übertemperaturlöser	1	44.157
29	Übertemperaturlöser	2	44.169
30	Deckel für Übertemperaturlöser	2	44.182
31	Dichtung für Deckel Übertemperaturlöser	1	44.182 1
32	Dichtung für Deckel Klemmkasten	1	44.075 3

Kränzle therm 630

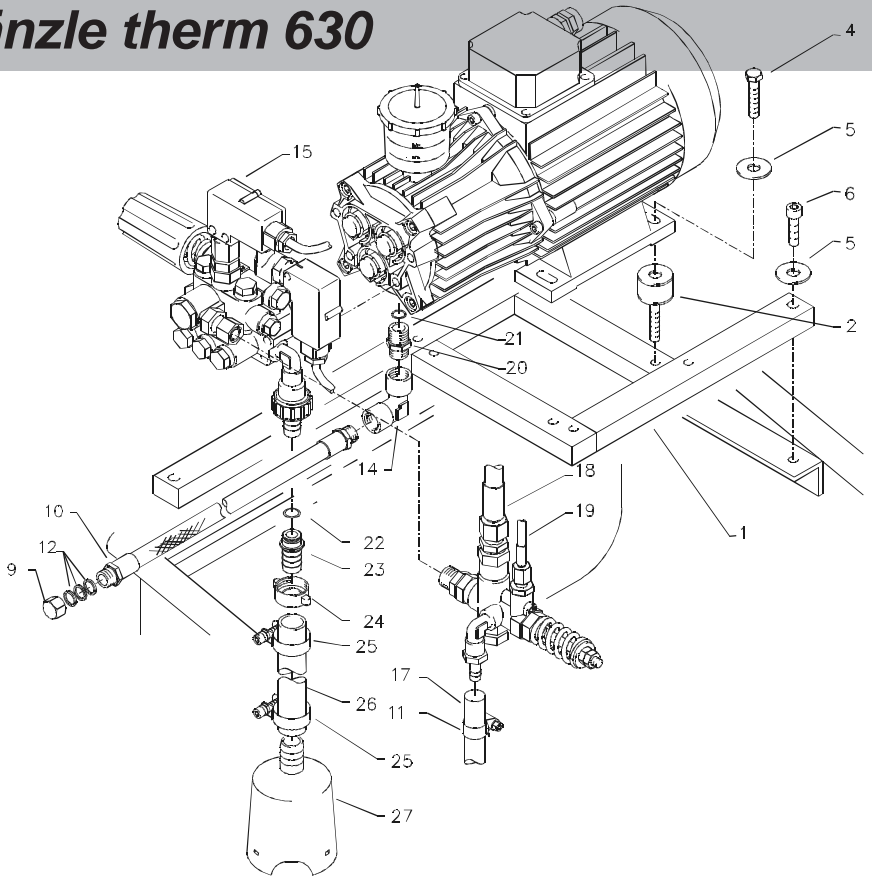

No.	Description	Qty.	Order No.
1	Aggregathalterung	1	44.013
2	Schwingmetall 30 x 30	4	44.227
4	Sechskantschraube M 8 x 25	4	44.137
5	Unterlegscheibe 8,4 DIN 9021	7	41.409
6	Innensechskantschraube M 8 x 30	3	41.036 1
9	Verschlusskappe	1	44.130
10	Ölablassschlauch	1	44.128 1
12	Kupferdichtring	3	14.149
14	Winkel 3/8" IG/IG	1	44.138
15	Druckschalter kpl. mit Kabel	2	44.120
17	By-Pass-Verbindungsschlauch	1	44.097
18	Hochdruckschlauch 360 mm	1	44.093
19	Druckmessleitung	1	44.102
20	Doppelnippel M18x1,5 IG x 3/8" IG	1	44.139
21	O-Ring	1	15.005 1
22	O-Ring 13 x 2,6	1	13.272
23	Schlauchtülle für Sauganschluß	1	44.126 1
24	Schlauchverschraubung 3/4" x 19	1	44.122
25	Schlauchschele 20 - 25	2	44.054 1
26	Ansaugschlauch	1	44.096
27	Saugglocke mit Sieb	1	15.038 5

Kränzle therm 630

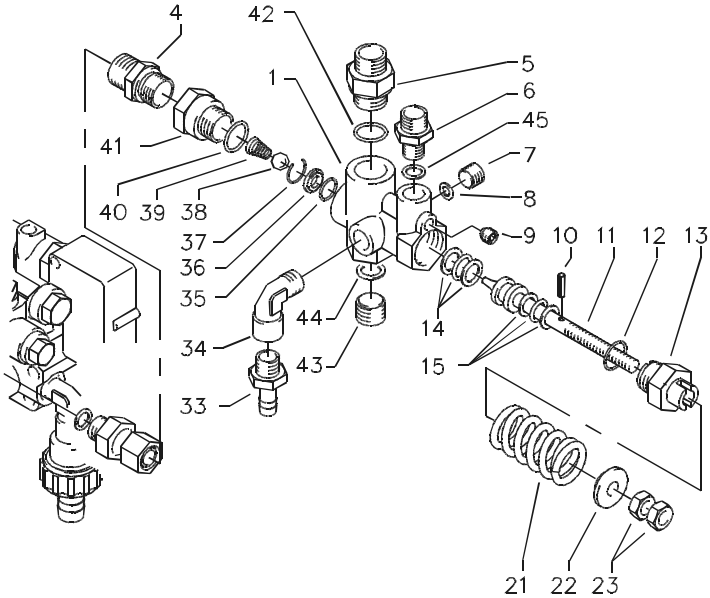

No.	Description	Qty.	Order No.
1	Ventilkörper	1	14.145
4	Ermetoverschraubung R 3/8" x 12 mm	2	40.076
5	Ausgangsteil	1	14.115 2
6	Ermetoverschraubung R1/4" x 4 mm	1	44.175
7	Stopfen R1/4"	1	13.387
8	O-Ring	1	13.275
9	Stopfen M 10 x 1	1	13.158
10	Spanstift	1	14.148
11	Steuerkolben	1	14.133
12	O-Ring	1	13.150
13	Kolbenführung	1	14.130
14	Parbaks 16 mm	1	13.159
15	Parbaks 8 mm	1	14.123
21	Ventilfeder	1	14.125
22	Federdruckscheibe	1	14.126
23	Sechskantmutter M 8 x 1	2	14.144
33	Schlauchtülle 1/4" x 6	1	44.053
34	Einschraubwinkel	1	40.121
35	O-Ring 11 x 1,44	1	12.256
36	Edelstahlsitz	1	14.118
37	Sprengtring	1	13.147
38	Edelstahlkugel 8,5 mm	1	13.148
39	Edelstahlfeder	1	14.119
40	O-Ring 15 x 2	1	13.150
41	Eingangsstück R3/8"	1	13.136
42	O-Ring	1	13.150
43	Stopfen R3/8"	1	14.139
44	Dichtring	1	14.149
45	Dichtring	2	13.275

Waterflow detector

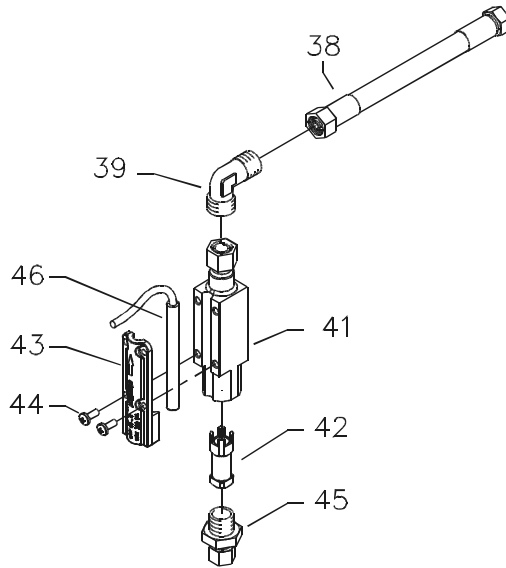

No.	Description	Qty.	Order No.
38	Hochdruckschlauch 225 mm lang	1	44.093 2
39	Winkelverschraubung 12L x 12L	1	42.630
41	Grundkörper Strömungswächter	1	12.601
42	Strömungskörper	1	12.602
43	Abdeckung	1	12.603
44	Schraube M 4 x 10	4	43.470
45	Eingangsteil 3/8" x 12 mit Mutter und Schneidring	1	12.604
46	Magnetschalter	1	40.594
Waterflow detector compl. Pos. 41 - 46			12.600 1

Transmission unit

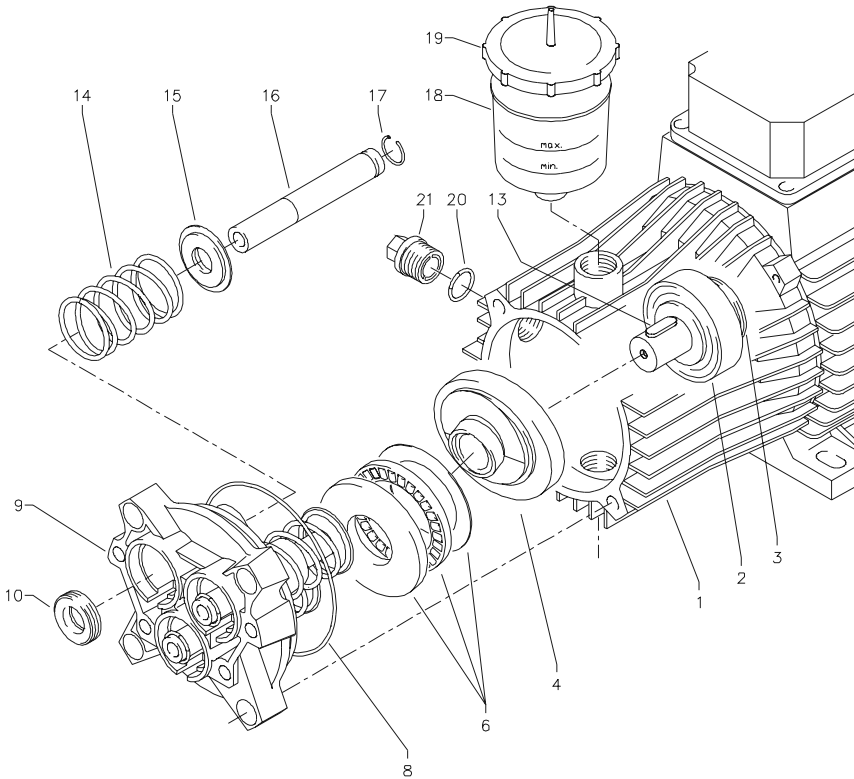

No.	Description	Qty.	Order No.
1	Motor 2,2 kW 230 V	1	24.012
2	Schulterlager	1	41.027
3	Öldichtung 25 x 35 x 7	1	41.024
4	Taumelscheibe 12,5°	1	46.542-12,5
6	Axial-Rollenlager 3-teilig	1	46.543
8	O-Ring 88 x 2	1	41.021 1
9	Gehäuseplatte 18 mm	1	41.020 2
10	Öldichtung 18 x 28 x 7	3	41.031
13	Passfeder 6 x 6 x 20	1	41.483 1
14	Plungerfeder	3	41.033
15	Federdruckscheibe	3	41.034
16	Plunger 18 mm	3	41.032 1
17	Sprengring	3	41.035
18	Ölbecher	1	41.622
19	Deckel für Ölbecher	1	41.023
20	O-Ring 12 x 2	1	15.005 1
21	Verschlusschraube M 18 x 1,5	1	41.011

Valve housing

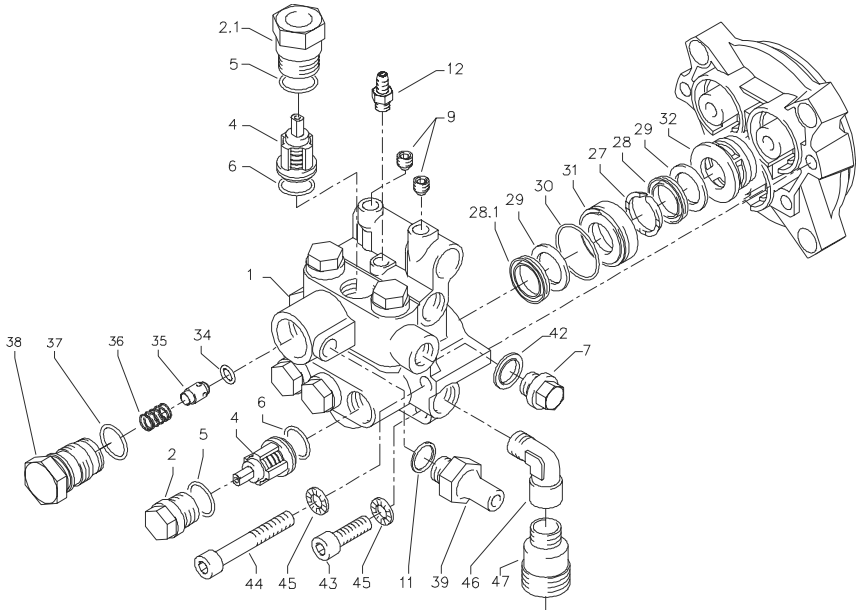

No.	Description	Qty.	Order No.
1	Ventilgehäuse	1	42.160
2	Ventilstopfen	5	41.714
2.1	Ventilstopfen mit R1/4" IG	1	42.026 1
4	Ventile (grün) für APG-Pumpe	6	41.715 1
5	O-Ring 16 x 2	6	13.150
6	O-Ring 15 x 2	6	41.716
7	Dichtstopfen R1/4" mit Bund	1	42.103
9	Dichtstopfen M 8 x 1	2	13.158
10	O-Ring 18 x 2	1	43.446
11	Aluminium - Dichtring	3	13.275
12	Saugzapfen Schlauchanschluß	1	13.236
27	Druckring	3	41.018
28	Manschette 18 x 26 x 4/2	3	41.013
28.1	Gewebemanschette 18 x 26 x 5,5/3	3	41.013 1
29	Backring 18 mm	6	41.014
30	O-Ring	3	40.026
31	Leckagering 18 mm	3	41.066
32	Zwischenring 18 mm	3	41.015 2
34	O-Ring 6 x 3	1	14.121
35	Rückschlagkörper	1	14.122
36	Rückschlagfeder	1	14.120
37	O-Ring 18 x 2	1	43.446
38	Ausgangsteil	1	42.166
39	Ausgangsteil Pumpe R1/4" x 12	1	44.215
42	Kupferring	1	42.104
43	Innensechskantschraube M 8 x 30	2	41.036 1
44	Innensechskantschraube M 8 x 55	2	41.017 1
45	Sicherungsring	4	40.054
46	Einschraubwinkel R3/8" IG/AG	1	40.121
47	Sauganschluß	1	41.016

Pump motor

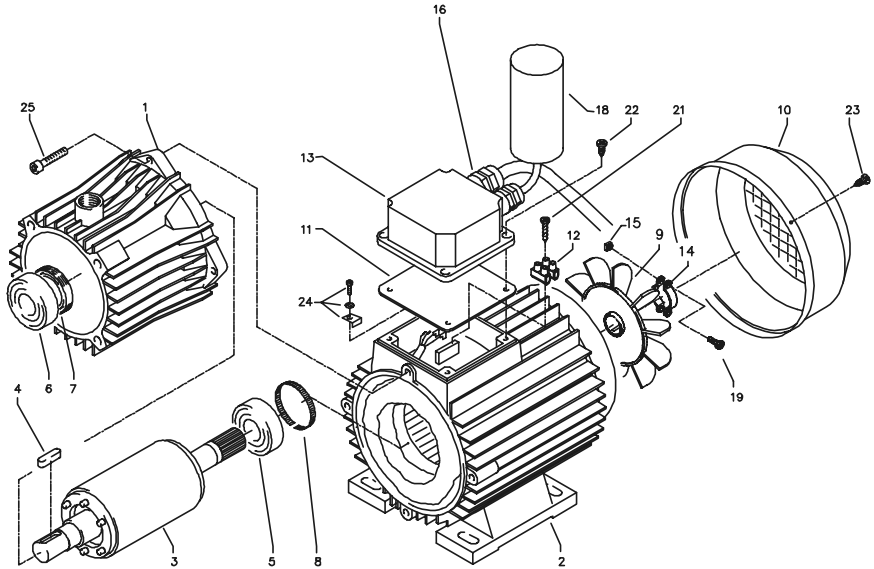

No.	Description	Qty.	Order No.
1	Ölgehäuse	1	41.417
2	Stator BG90 230V / 50Hz	1	23.003
2.1	Stator BG90 230V / 60Hz	1	23.003 1
3	Rotor für 2,2 kW - 50Hz Motor	1	43.317
3.1	Rotor für 2,2 kW - 60Hz Motor Silumin	1	43.523
4	Paßfeder 6 x 6 x 20	1	41.483 1
5	Kugellager	1	43.317
6	Schulterlager	1	41.027
7	Öldichtung 25 x 35 x 7	1	41.024
8	Toleranzhülse	1	43.330 1
9	Lüfterrad BG 90	1	41.118 1
10	Lüfterhaube BG 90	1	41.120 1
11	Flachdichtung	1	41.086
12	Lüsterklemme 2,5 mm ² 2-polig	1	43.031
13	Klemmkasten	1	41.090 2
14	Klemmschelle für Lüfterrad	1	43.456
15	Vierkantmutter	2	43.323
16	PG-Einschub mit 1 PG-Verschraubung	1	41.090 4
18	Kondensator 70 µF	1	43.322
19	Schraube M 4 x 12	2	41.489
21	Blechschaube 2,9 x 16	1	43.036
22	Blechschaube 5 x 12	4	41.089
23	Blechschaube 4 x 9	4	41.079
24	Erdungsklemme kpl.	1	43.038
25	Innensechskantschraube M 6 x 30	4	43.037

Gun

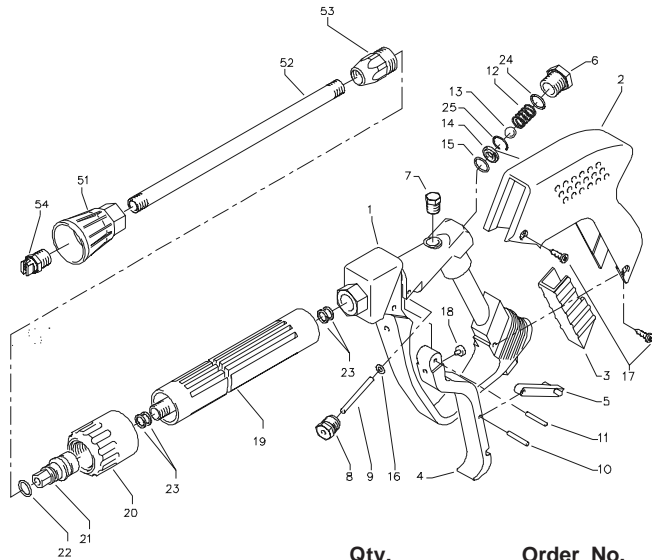

No.	Description	Qty.	Order No.
1	Ventilkörper kunststoffumspritzt	1	12.294
2	Schutzhülse	1	12.295
3	Abdeckschutz	1	12.296
4	Betätigungshebel	1	12.298
5	Sicherungshebel	1	12.149
6	Abschlußschraube M 16 x 1	1	12.247
7	Stopfen	1	12.287
8	Gewindeführungshülse R 1/4" AG	1	12.250
9	Aufsteuerbolzen	1	12.284
10	Stift	1	12.148
11	Lagernadel	1	12.253
12	Edelstahlfeder	1	12.246
13	Edelstahlkugel	1	12.245
14	Edelstahlsitz	1	13.146
15	O-Ring 11 x 1,44	1	12.256
16	O-Ring 3,3 x 2,4	1	12.136
17	Blechschaube 3,9 x 8	4	12.297
18	Druckstück	1	12.252
19	Rohr kunststoffumspritzt	1	15.004 5
20	Überwurfmutter ST30 M22x1,5	1	13.276 1
21	Außensechskantnippel R 1/4" IG	1	13.277 1
22	O-Ring 9,3 x 2,4 Viton	1	13.273 1
23	Alu-Dichtring	4	13.275
24	O-Ring 15 x 1,5	1	12.129 1
25	Sicherungsring	1	12.258
51	Düsenschutz	1	26.002
52	Rohr 396 mm; bds. R1/4"	1	12.385
53	ST 30 Nippel M 22 x 1,5 / R1/4" m. ISK	1	13.370
54	Flachstrahldüse	1	D25045

Rep.-Satz "Starlet II"

bestehend aus je 1x Position:
9; 13; 14; 15; 16; 25

12.299

Hose drum

(Special accessory)

Supplementary Parts: 44.152

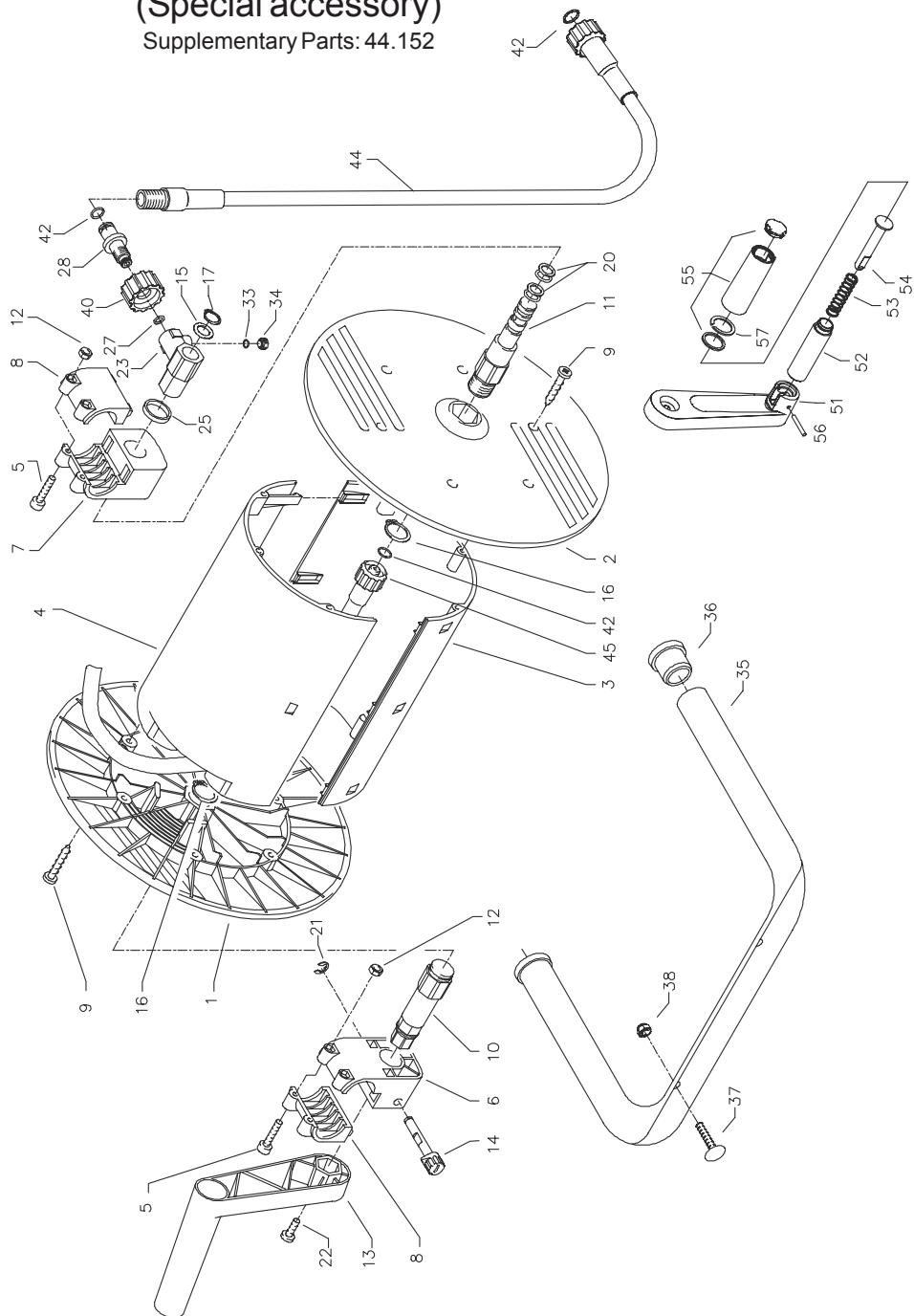

Kränzle therm 630

Spare part list KRÄNZLE therm Hose reel

Pos.	Description	Qty	Order No.	Pos.	Description	Qty	Order No.
1	Seitenschale Schlauchführung	1	40.302	35	Haltebügel	1	44.143
2	Seitenschale Wasserführung	1	40.301	36	Gummistopfen	2	40.208 1
3	Trommel Unterteil	1	40.304	37	Schloßschraube M 8 x 40	2	44.159
4	Trommel Oberteil	1	40.303	38	Elastic-Stop-Mutter M 8	2	41.410
5	Innensechskantschraube M 4 x 25	4	40.313	40	Überwurfmutter	1	13.276 2
6	Lagerklotz mit Bremse	1	40.306	42	O-Ring 9,3 x 2,4	4	13.273
7	Lagerklotz links	1	40.305	44	Verbindungsschlauch NW 8 1 m	1	44.160
8	Klemmstück	2	40.307	45	Hochdruckschlauch NW 8 20 m	1	41.083 3
9	Kunststoffschraube 5,0 x 20	12	43.018	51	Kurbelarm	1	40.309 1
10	Antriebswelle	1	40.310	52	Hülse	1	40.309 2
11	Welle Wasserführung	1	40.311	53	Druckfeder	1	40.309 3
12	Elastic-Stop-Mutter M 4	4	40.111	54	Bolzen	1	40.309 4
13	Handkurbel klappbar	1	40.309 9	55	Griff mit Kappe und Gleitscheibe	1	40.309 5
14	Verriegelungsbolzen	1	40.312	56	Spannstift 4 x 28	1	40.309 6
15	Scheibe MS 16 x 24 x 2	1	40.181	57	Flachsprengring SW18	1	40.309 8
16	Weilensicherungsring 22 mm	2	40.117				
17	Weilensicherungsring 16 mm	1	40.182				
20	Parbaks 16 mm	2	13.159				
21	Sicherungsscheibe 6 DIN6799	1	40.315		Schlauchtrommel kpl.		41.259
22	Schraube M 5 x 10	1	43.021		ohne Schlauch, ohne Haltebügel		
23	Drehgelenk	1	40.167				
25	Distanzring	1	40.316		Haltebügel kpl.		44.143 1
27	O-Ring 6,86 x 1,78	1	40.585		bestehend aus Pos. 35 - 38		
28	Anschlußstück	1	40.308				
33	O-Ring 6 x 1,5	1	13.386		Kurbel kpl.		40.309 9
34	Stopfen M 10 x 1	1	13.385		bestehend aus Pos. 51 - 57		

Pipeline plan

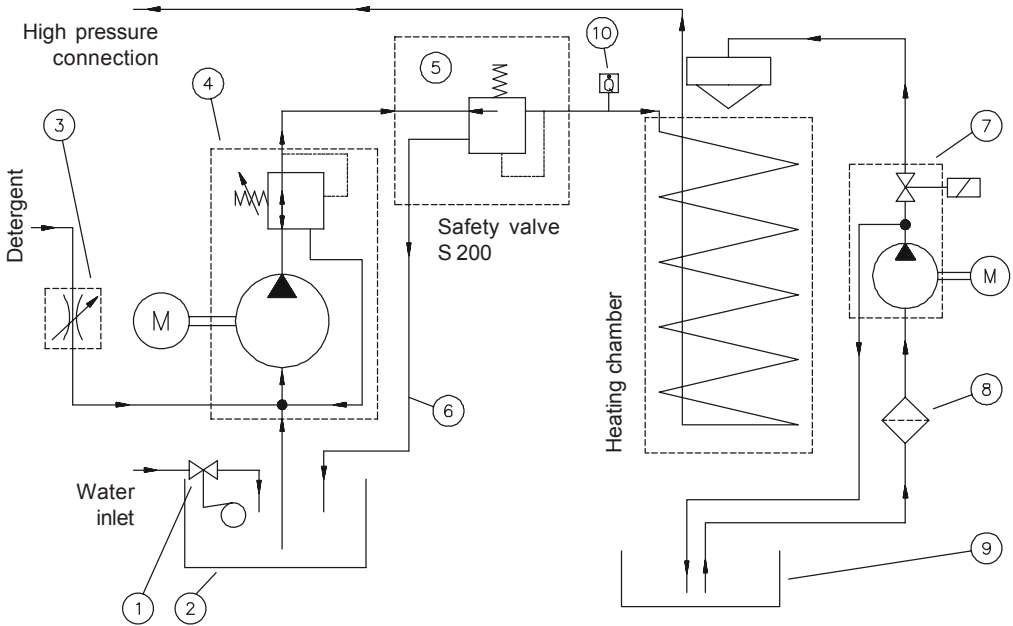

- 1 Float valve, water inlet
- 2 Water tank
- 3 control valve, detergent
- 4 High pressure pump with integrated unloader valve
- 5 Safety valve

- 6 Excess pressure line, safety valve
- 7 Fuel pump with magnetic valve
- 8 Fuel filter
- 9 Fuel tank
- 10 Waterflow detector



I. Kränzle GmbH
Elpke 97 . 33605 Bielefeld

EC declaration of conformity

We hereby declare,
that the high-pressure models:

Kränzle therm 630

(techn. documentation available from):

**Manfred Bauer, Fa. Josef Kränzle
Rudolf-Diesel-Str. 20, 89257 Illertissen**

comply with the following guidelines and
specifications and their amendments for
high-pressure cleaners:

**Machine guideline 89/392/EEC
Low voltage guideline 73/23 EEC
Specification for electromagnetic
compatibility 89/336 EEC
Outdoor noise directive 2000/14/EC,
Art. 13, High-pressure water jet machines
Appendix 3, part B, chapter 27**

Sound power level measured:
 guaranteed:

**86 dB (A)
88 dB (A)**

Applied specifications and
standards:

**EN 60 335-2-79 / A1:2001
EN 55 014-1 / A2:2002
EN 55 014-2 / A1:2001
EN 61 000-3-2 / A14:2000
EN 61 000-3-3 / A1:2001**

Bielefeld, den 08.09.05

Droitsch
(Managing Director)

Inspection Sheet

Customer: _____

Mixing facility:

Number of slots: 4

Diameter of hole: 22 mm

All lines connected

Hose clamps tight

Screws all installed and tightened

Ignition cable plugged in

Visual check carried out

Brake function checked

Sealing check:

Float box filled and checked

Water inlet checked for tightness

Float valve function checked

Machine checked for tightness under pressure

Flow controller function checked

Electrical check:

Earth line checked

Current intake

Operating pressure:

Switch-off pressure:

Steam phase checked

Chemical valve checked

Start/Stop automatic and
re-run delay checked

Kränzle therm 630

Fuel warning switch checked

Thermostat function checked

Burner function checked:

Water temperature reached:

70	72	74	76	78	80	82	84	86	88	90
----	----	----	----	----	----	----	----	----	----	----

 °C

Fuel pressure:

8	8,5	9	9,5	10	10,5	11	11,5	12
---	-----	---	-----	----	------	----	------	----

 bar

Measured soot count:

0	1	2	3
---	---	---	---

Result of emissin analysis:

Safety equipment sealed with lacquer

Name of inspector: _____

Date: _____

Signature: _____

Inspection report for HP cleaners

Inspection report on annually carried out Labour Safety Inspection (UVV) according to the Guidelines for Liquid Spray Equipment. (This inspection sheet serves as proof for the completion of the retest and must be kept carefully!)

Owner: _____ Type: **therm 630** _____ Built: _____

Address: _____ Serial no.: _____

Rep.-order-no.: _____

Scope of inspection:	ok		repair- ed
	yes	no	
Type plate (on hand)			
Operating manual (on hand)			
Protective covering, -device			
Pressure line (tightness)			
Pressure gauge (function)			
Float valve (tightness)			
Spraying device (marking)			
HP-hose/ connector (damage, marking)			
Safety valve opens at 10% / 20% exceeding of operating pressure			
Pressure reservoir			
Heating oil line (tightness)			
Solenoid valve (function)			
Thermostat (function)			
Flow controller (function)			
Power cable (damage)			
Power plug (damage)			
Protective conductor (connected)			
Emergency Off Switch (function)			
On/Off-switch			
Water quantity safety device (function)			
Used chemicals			
Allowed chemicals			

Inspection data:	determ. value	set value
High-pressure nozzle		
Operating pressurebar		
Cutting-off pressure.....bar		
Smoke spot number.....acc. to Bacharach scale		
CO ² -value.....% CO ²		
Efficiency rating.....%		
Conductor resist. not exceeded / value:		
Insulation		
Leakage current:		
Gun locked		

Inspection result (tick):

- The appliance was checked by an expert according to the Guidelines for Liquid Spray Equipment, the defects found have been rectified so that the Labour Safety can be confirmed.
- The appliance was checked by an expert according to the Guidelines for Liquid Spray Equipment. The Labour Safety cannot be confirmed unless the defects found are rectified by repair or replacement of the faulty parts.

The next retest according to the Guidelines for Liquid Spray Equipment has to be carried out by:

Month: _____ Year: _____

Place, Date: _____

Signature: _____

Inspection report for HP cleaners

Inspection report on annually carried out Labour Safety Inspection (UVV) according to the Guidelines for Liquid Spray Equipment. (This inspection sheet serves as proof for the completion of the retest and must be kept carefully!)

Owner: _____ Type: **therm 890/1160** Built: _____

Address: _____ Serial no.: _____

Rep.-order-no.: _____

Scope of inspection:	ok		repair- ed
	yes	no	
Type plate (on hand)			
Operating manual (on hand)			
Protective covering, -device			
Pressure line (tightness)			
Pressure gauge (function)			
Float valve (tightness)			
Spraying device (marking)			
HP-hose/ connector (damage, marking)			
Safety valve opens at 10% / 20% exceeding of operating pressure			
Pressure reservoir			
Heating oil line (tightness)			
Solenoid valve (function)			
Thermostat (function)			
Flow controller (function)			
Power cable (damage)			
Power plug (damage)			
Protective conductor (connected)			
Emergency Off Switch (function)			
On/Off-switch			
Water quantity safety device (function)			
Used chemicals			
Allowed chemicals			

Inspection data:	determ. value	set value
High-pressure nozzle		
Operating pressurebar		
Cutting-off pressure.....bar		
Smoke spot number.....acc. to Bacharach scale		
CO ² -value.....% CO ²		
Efficiency rating.....%		
Conductor resist. not exceeded / value:		
Insulation		
Leakage current:		
Gun locked		

Inspection result (tick):

- The appliance was checked by an expert according to the Guidelines for Liquid Spray Equipment, the defects found have been rectified so that the Labour Safety can be confirmed.

- The appliance was checked by an expert according to the Guidelines for Liquid Spray Equipment. The Labour Safety cannot be confirmed unless the defects found are rectified by repair or replacement of the faulty parts.

The next retest according to the Guidelines for Liquid Spray Equipment has to be carried out by:

Month: _____ Year: _____

Place, Date: _____

Signature: _____

